

Asia Pacific Research Initiative for Sustainable Energy Systems 2012 (APRISES12)

Office of Naval Research
Grant Award Number N00014-13-1-0463

Wave Energy Test Site ROV Operational Assessments Report

Task 4.2

Prepared For
Hawaii Natural Energy Institute

Prepared By
Sea Engineering, Inc.

June 2018



HNEI
Hawai'i Natural Energy Institute
University of Hawai'i at Mānoa



University of Hawai'i Office of Research Services: Asia-Pacific Research Initiative for Sustainable Energy Systems 2012

Task 06: ROV Operational Assessments and Report #3 Task 06C: Final Report

Kāneʻohe Marine Corps Base, Oʻahu , Hawai'i



University of Hawai'i Office of Research Services: Asia-Pacific
Research Initiative for Sustainable Energy Systems 2012

Prepared by:

Sea Engineering, Inc.

863 N. Nimitz Hwy

Honolulu, HI 966817

Job No. 13001



1	INTRODUCTION	4
2	PROJECT LOCATION	5
3	SUMMARY OF TASKS	6
3.1	TASK 01: REQUIREMENTS ASSESSMENT	6
3.2	TASK 02: MARKET STUDY OF AVAILABLE ROVS	7
3.3	TASK 03: ROV PROCEDURAL ANALYSIS	7
3.4	TASK 004: ROV PURCHASE	8
3.5	TASK 005: ROV INSTALLATION ABOARD SITE-DEDICATED SUPPORT VESSEL	8
4	TASK 06 ROV OPERATIONAL ASSESSMENTS AND FINAL REPORT	10
4.1	TASK 06A: ROV OPERATIONAL ASSESSMENTS REPORT #1	10
4.2	TASK 06B: ROV OPERATIONAL ASSESSMENTS REPORT #2	11
5	TASK 06C: ROV FINAL REPORT	12
5.1	WETS INSPECTIONS	12
5.2	WETS DEEPWATER BERTH REPAIR	13
5.2.1	<i>ROV Support for WETS Deepwater Berth Repair</i>	13
5.2.2	<i>Unscheduled ROV Support</i>	13
5.3	WETS DECOMMISSIONING	13
5.4	COST ANALYSIS FOR LOCALLY AVAILABLE ROV	14
6	SUMMARY	16
	FIGURE 3-1. KĀNE‘OHE MARINE CORPS BASE HAWAI‘I – WAVE ENERGY TEST SITE	5

1 INTRODUCTION

In support of the University of Hawai‘i’s Project “Asia-Pacific Research Initiative for Sustainable Energy Systems 2012 (APRISSES12), Task 4.2, Wave Energy Testing”, Sea Engineering Inc. (SEI) was contracted to assess remotely operated vehicle (ROV) requirements at the U.S. Navy Wave Energy Test Site (WETS), conduct a market study of available ROV solutions, purchase an ROV to support University of Hawai‘i, Department of Energy, and US Navy Research objectives at WETS, and, through use of the ROV, to conduct an analysis of the utility and limitations of that ROV in support of wave energy test objectives.

The ROV will provide important research, maintenance and emergency response capabilities that are expected to greatly enhance the ability of the DOE and Navy at WETS.

Tasks under the Agreement for Services (MA150044) include:

- Task 001: Requirements Assessment
- Task 002: Market Study of Available ROVs
- Task 003: ROV Procedural Analysis
- Task 004: ROV Purchase
- Task 005: ROV Installation Aboard Site-Dedicated Support Vessel
- Task 06A: ROV Operational Assessments Report #1
- Task 06B: ROV Operational Assessments Report #2
- Task 06C: ROV Final Report

This report presents the results of Task 06C – ROV Final Report.

2 PROJECT LOCATION

ROV studies and operations are based on work anticipated at the Kāneʻohe Marine Corps Base (MCBH) Wave Energy Test Site (WETS). The Wave Energy Test Site is located on the windward side of the Island of Oʻahu, offshore of the Kāneʻohe Marine Corps Base Hawaiʻi. The test site is located northeast of Heʻeia Kea Small Boat Harbor within the security zone of MCBH. Key features at WETS, including the 30-meter test site, deep water wave energy test sites (comprised of 60 meter and 80 meter berths), Heʻeia Kea Small Boat Harbor, a dedicated vessel approved mooring area, Pyramid Rock, Battery French, and the MCBH Fuel Pier, are shown in Figure 2-1.

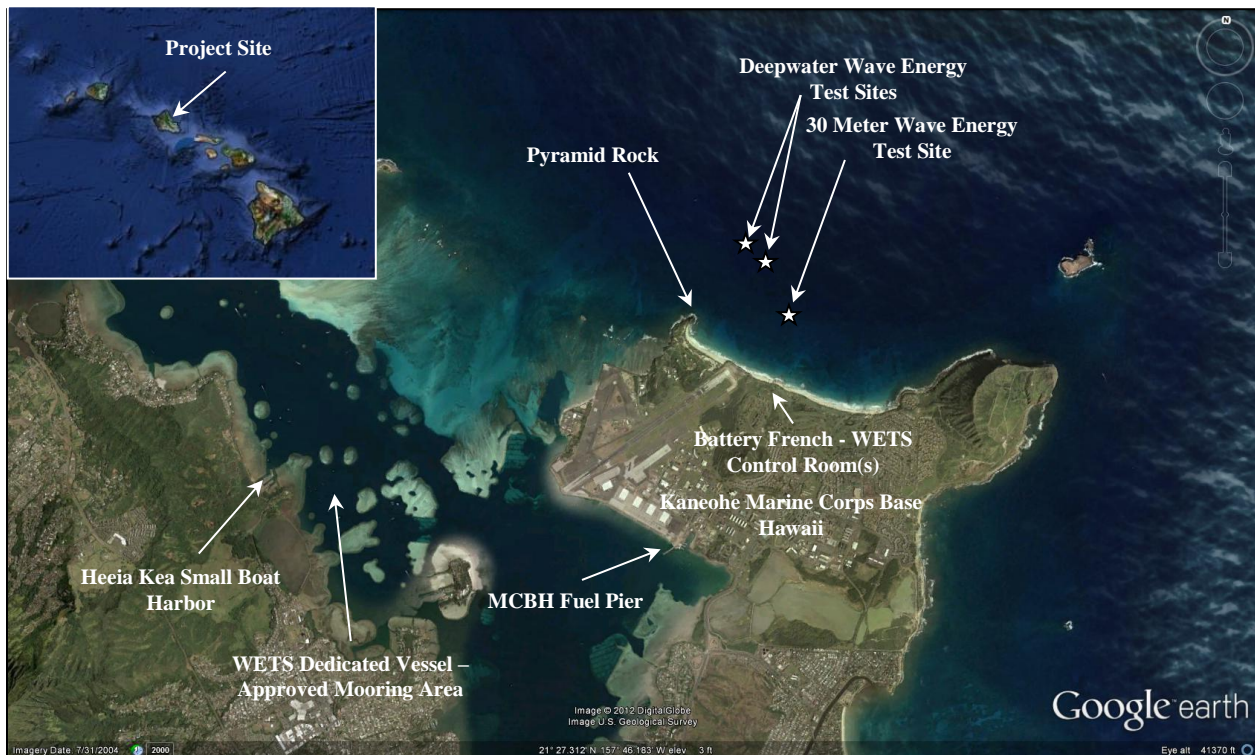

Figure 2-1. Kāneʻohe Marine Corps Base Hawaiʻi – Wave Energy Test Site

3 SUMMARY OF TASKS

Assessment and procurement of a support ROV for work at the MCBH Wave Energy Test Site was comprised of the following tasks:

- Task 1: Requirements Assessment
- Task 2: Market Study of Available ROVs
- Task 3: ROV Procedural Analysis
- Task 4: ROV Purchase
- Task 5: ROV Installation Aboard Site-Dedicated Support Vessel
- Task 6: ROV Operational Assessments and Final Report
 - Task 6a – Interim Operational Assessment #1
 - Task 6b – Interim Operational Assessment #2
 - Task 6c – Final Report

Each of the tasks is discussed in greater detail below. Reports, summarizing the work completed under Tasks 1 through 6b are included in appendices at the end of this final report.

3.1 TASK 01: REQUIREMENTS ASSESSMENT

SEI assessed activities expected at WETS that would require, or be made easier and more cost effective, through use of an ROV. Assessment was based on prior experience at WETS, assessment of maintenance, consultation with HNEI, NAVFAC, and prospective tenants, and other research. The assessment was to provide a list of specifications for a potential ROV purchase to support work at WETS.

Water depths at the deepwater berth of WETS are up to 150 meters deep at the offshore mooring anchors. Thus, the ROV must have the capability performing maintenance operations in 150 meters of water with moderate to strong currents. In addition, SEI developed the following objectives for ROV support based on market research, SEI's experience at WETS and with Ocean Powers Technology at their Oregon test site.

- High Resolution Video Inspection of Mooring Hardware, cables to shore, and deployed WEC Devices
- High Resolution Ecological Video Surveys at Deepwater Berths
- Ultrasonic Thickness Measurements of Mooring or WEC Device Hardware
- Maintenance and Salvage Support
 - Rigging Assistance
 - Shackle and Chain Cutting
 - Hawser Cutting
- Diver Assistance
- Site Decommissioning Assistance

These objectives lead to the following requirement for an ROV to operate at WETS:

- Minimum single 5-way manipulator capable of the following tasks:
 - Rigging Assistance
 - Line Cutting
 - Recovery Capabilities
- High Resolution Video Camera(s)
- Additional Tooling Capabilities
 - Grinding Disc
 - Ultrasonic Thickness Gauge
 - Cathodic Potential Gauge

The detailed requirements assessment is included in Appendix I of the report.

3.2 TASK 02: MARKET STUDY OF AVAILABLE ROVS

Based on the findings of Task 01, SEI completed a market study of available industry technology and provided HNEI with a report highlighting the range of ROV products and providing a recommendation for a vehicle purchase.

SEI identified eleven ROV manufactures and evaluated their light work class ROVs. From these 11 manufactures, three manufacture models suitable for work at WETS, including SMD, Saab, and Sub-Atlantic Forum. Based on additional market research, durability, price and peer to peer review of owners of various ROVs, the Sub-Atlantic Forum Super Mohawk was chosen and recommended to HNEI.

The detailed market study of available ROVs is included in Appendix II of the report

3.3 TASK 03: ROV PROCEDURAL ANALYSIS

SEI has developed drawings, and documented planned deployment, recovery, maintenance and storage procedures for the Super Mohawk ROV. Deployment procedures include the ROV, control container, generator, and winch. The control van (a 20-ft insulated conex) houses the necessary equipment for the operation of the Super Mohawk ROV.

The procedural analysis for deployment and recovery of the ROV can be applied to the site-dedicated vessel, Kūpa'a, SEI's other work vessel, Huki Pau, or any other vessels of opportunity outfitted with lifting capability and workspace for the equipment.

Detailed ROV procedural analysis is included in Appendix III of the report.

3.4 TASK 004: ROV PURCHASE

SEI purchased the Forum Sub-Atlantic Super Mohawk II ROV for a total price of £ 467,332 (\$673,875 on April 4, 2016). Payments for the Mohawk II ROV were made over 4 installments, associated with schedule goals during the production of the vehicle. These included; contract execution, frame load test, vehicle integration and the facility acceptance tests (FAT). Additional purchases were required to setup the necessary ancillary support and operational systems including buildout of an insulated 20-ft container, umbilical deck winch, 40kW generator, ROV spare parts, and a second controller for the manipulator. On-site training with Forum personnel was also procured. The additional costs beyond the contractual not-to-exceed (NTE) cost were incurred by Sea Engineering, Inc. as part of the cost share on the project.

The detailed ROV Purchase Report is included in Appendix IV.

3.5 TASK 005: ROV INSTALLATION ABOARD SITE-DEDICATED SUPPORT VESSEL

The Forum SuperMohawk II ROV support system has been designed to be modular to allow the ROV to be operated from multiple vessels including SEI's *Kūpa 'a*, the WETS site dedicated vessel; SEI's *Huki Pau*, SEI's current workboat and WETS support vessel; and other support vessels such as a Healy Tibbitts crane barge if needed.

The ROV and support system installation and integration was completed in two phases, (1) dry testing of the ROV and its components at SEI's Nimitz offices, and (2) wet testing onboard the *Huki Pau* alongside Pier 26 in Honolulu Harbor.

The dry tests and mobilization tasks included the following:

- Winch hydraulics testing and repair
- Slip ring removal and reinstallation
- Fixed junction box termination
- Tether installation on winch drum
- Rotating junction box termination
- Generator supply voltage test
- Transformer supply voltage test
- SCU supply voltage test
- Voltage tests in the ROV pods
- Fiber loss through the system
- Console and display setup
- Thruster testing
- Camera setup
- Hydraulic manipulator testing
- SubCan control software setup
- Cable cutter test

The wet tests included the following:

- Buoyancy and trim testing
- ROV auto function calibration (auto heading, auto attitude, auto depth, gyro stability)
- Cable cutter test
- ROV controller testing
- Hydraulic function testing (twin manipulator and single manipulator with cutoff wheel)
- USBL positioning system setup

The detailed ROV Installation Report is included in Appendix V of the report.

4 TASK 06 ROV OPERATIONAL ASSESSMENTS AND FINAL REPORT

Task 06 of the APRISES12 contract included analysis and evaluation of the utility of the ROV at WETS over the timeline of the contract. The objective of Task 6 is to present lessons learned from the integration and initial field testing as well as identify recommendations for changes, upgrades and other adjustments to better equip the ROV for work at WETS. The analyses included comparison of the cost of inspection and maintenance activities at WETS with and without a dedicated ROV.

Wave Energy Deployments at WETS, particularly the deepwater berths, have been delayed several times. These delayed schedules have meant that scheduled and unscheduled work for the ROV at WETS has not been required during the term of this support contract. However, it is anticipated that several commercial scale wave energy devices are scheduled for deployment within the next few years. SEI has teamed with these developers and anticipates that utilization of the ROV will increase significantly with an increase in deepwater berth usage.

Task reports 6A and 6B, summarized below and included in Appendices VI and VII, summarize SEI's integration efforts as well as additional customization and improvements to the ROV system in preparation for additional WETS work.

4.1 TASK 06A: ROV OPERATIONAL ASSESSMENTS REPORT #1

As part of the integration of the ROV into SEI's site support vessels, SEI conducted installation operations for the ROV in early November 2017. As described in Section 4.5 above, the installation was completed in two phases, (1) dry testing of the ROV and its components at SEI's Nimitz offices, and (2) wet testing onboard the Huki Pau alongside Pier 26 in Honolulu Harbor.

During the initial integration period SEI identified the following items to improve upon, modify, or replace:

- Develop documentation procedures and template reports and logs to facilitate useful databases for operations of the ROV, and any changes.
 - Maintenance Logs
 - Modification Reports
 - Pre-dive Logs
 - Dive Logs
 - Post-dive Logs
- Remove the A-frame and level wind of the winch as they will not be used to lift the ROV.
- Replace the fixed junction box on the winch.
- Modify the rotating junction box on the winch to allow for servicing with the tether on.
- Update ROV control software (SubCan) to make use of the bear paw controls.
- Re-termination of the fiber optics and electrical connectors on the tether and spare tether.

Additional modifications to the deck cable connections were also requested by FORUM.

The detailed ROV Operational Assessment Report is included in Appendix VI of the report

4.2 TASK 06B: ROV OPERATIONAL ASSESSMENTS REPORT #2

Following initial improvements completed in Task 06a (see Section 5.1), SEI continued with modifications to the deck winch with the replacement of the fixed junction box and the reduction in height of the rotating junction box. These modifications increase the ease of servicing the terminations inside the boxes. Specifically, the terminations can be accessed with the umbilical still on the winch drum. This modification eliminates hours of downtime offshore, or possibly transit back to the dock if re-termination is required during operations.

SEI also updated the Subcan software, which allows the operator to use the Schilling Bear Paw to control the second manipulator. This modification significantly increases operator capabilities for manipulating and operating the second manipulator during difficult operations.

The Applied Acoustic USBL system was integrated with the ROV. This will allow the tracking of the ROV and the positioning of subsurface features. The USBL ROV position will be displayed in conjunction with the pertinent maps and overlays within Hypack navigation software. This display will aid navigation and positioning of the ROV and surface vessel.

The detailed ROV Operational Assessment Report is included in Appendix VII of the report

5 TASK 06C: ROV FINAL REPORT

Task 06C represents the final report associated with Subaward Number MA15004, “Asia-Pacific Initiative for Sustainable Energy Systems 2012”, Task 4.2 Wave Energy Testing. Task 06C provides a summary of work completed with the ROV through the contract timeline as well as a look-ahead at anticipated tasks and a cost assessment compared with off-island options.

The bathymetry around the islands of Hawai'i is typical of a volcanic island. Air diving depths are located close to shore, with general water depths dropping quickly within a short distance from the shoreline. Hawai'i's minimal subsea infrastructure and limited offshore industries have meant that no market has existed to support the purchase and operational costs of a light-work class ROV in Hawai'i.

Prior to SEI's purchase of the Super Mohawk 36, the only work class ROV was owned by the University of Hawai'i, who owns and operates a DOER H6000, “*Lu'ukai*”. UH's ROV is setup for scientific research and support at the Aloha Station, and other deepwater areas. As such, it is outfitted with a Tether Management System, and is operated off larger support vessels, like the *Kilo Moana*. The *Lu'ukai* is not marketed for commercial work in the nearshore waters of the Hawaiian Islands.

The procurement of SEI's Super Mohawk 36 ROV is intended to provide support to infrastructure shallower than the Aloha Station (4,800 meter water depth), but deeper than air-diving depth of 190 fsw. The MCBH Wave Energy Test Site deepwater berths, located in 60 and 80 meters water depth, are too deep for air-diving operations at the seafloor, but are relatively shallow for larger operations associated with the *Lu'ukai*. Additionally, due to the inherent dangers of diving, USACE EM385-1-1 regulations, followed by the Navy for civilian diving operations, specify that work that could be done utilizing an ROV will be conducted using an ROV unless sufficient evidence can be shown that diving is either required or safer.

With the construction and operation of the WETS deepwater berths, relatively significant infrastructure now exists that will require scheduled and unscheduled maintenance and support in water depths too deep for air diving practices. Scheduled and unscheduled WETS activities for the Super Mohawk 36 at WETS are discussed in greater detail below.

5.1 WETS INSPECTIONS

The Super Mohawk ROV was outfitted with high-resolution video capability as well as dual manipulator arms and the capability to be outfitted with non-destructive testing (NDT) equipment, such as ultrasonic thickness gauges and cathodic protection measurement sensors. These combined capabilities can be used at WETS for scheduled inspection events to identify the current condition of deepwater mooring hardware (chain, sinker blocks, and anchors), cable node, WEC device umbilicals and any other components below diver depth.

There are three planned inspections with the Super Mohawk ROV funded at the WETS site through June 2019. The inspections will provide high-resolution video of the chain, anchors, cable node and shore cable connection.

An additional 9 inspections are expected to be funded for 2019 and beyond. As the infrastructure at the site matures, NDT testing, including ultrasonic thickness or cathodic protection may be added to evaluate long-term conditions of the infrastructure hardware components.

5.2 WETS DEEPWATER BERTH REPAIR

The current infrastructure at the WETS 60 and 80-meter berths requires retrofit and repairs prior to installation of the next commercial scale WEC devices. The current configuration at the deepwater berths includes B1 and B2 moorings with failed chain links, while the other four moorings A1, A2, A3 and B3 remain intact. B1 and B2 surface floats, and subsequent chain have been recovered and relocated to Pearl Harbor. However, the remainder of chain, sinker blocks and anchors remain in-situ on the seafloor. Repair work includes recovering the chain for B1 and B2 from the seafloor onto the barge so that required repairs can be completed.

Additionally, the bend strain relief (BSR) on the cable node at the 60 meter berth was damaged during deployment. As part of the scheduled deepwater berth repairs, the BSR was replaced.

These repairs are being made ahead of the next deepwater berth tenant, Ocean Energy. Ocean Energy plans to install their grid connected device in late 2018 at the 60 meter berth.

5.2.1 ROV Support for WETS Deepwater Berth Repair

The chain for B1 and B2 mooring legs at the 80-meter site requires recovery to the work barge for retrofit and repair. The Super Mohawk 36 will be utilized for chain recovery. The ROV manipulator arm and high thrust capability will be used to carry a messenger line with a rigid tip to the chain. Once onsite, the ROV would feed the line through the chain and return to the work barge. The messenger line would then be used to pull the main pickup line through the chain for recovery with a large deck winch mounted on the barge.

In addition to the messenger line work, SEI's ROV may be utilized to rig and assist in recovery of disconnected anchor blocks. Anticipated work days onsite are 3 to 4 days for ROV assistance.

As part of the BSR repair Ocean Energy plans to utilize the recovery of the cable node to install their umbilical ahead of their WEC deployment. Depending on final design of the umbilical and temporary moorage on-site, the Super Mohawk 36 may be utilized to rig the spectra line from SEI's Braden winch, scheduled to be installed on the OE device for umbilical makeup, directly to the end of the umbilical for recovery. This operation would be 1 day onsite.

5.2.2 Unscheduled ROV Support

SEI anticipates that the addition of commercial scale WEC devices will lead to an increased need for deepwater support. At a minimum, SEI anticipates additional, unscheduled inspections to visually check on condition of components. Other tasks may be related to gravity based anchors, suspended from the floor of the WEC devices, but beyond diver depth, umbilical's or any additional new technology that developers propose as larger scale devices are proposed for WETS.

5.3 WETS DECOMMISSIONING

At the end of the WETS project, the site will be decommissioned, requiring removal of all hardware and mooring components to return the site to its original condition. The ROV will have an active role in decommissioning WETS. The Super Mohawk 36, will be able to utilize its scanning sonar and high resolution cameras to locate and identify subsea targets. The ROVs dual manipulator arms, anvil cutter

and hydraulic cutting disc will be capable of assisting in rigging and removal of in-situ hardware and lost gear. Smaller hardware, less than 10 tons, can be recovered using the WETS dedicated vessel, Kūpa‘a. It is anticipated that WETS decommissioning of the deepwater site could take up to 10 days to complete.

5.4 COST ANALYSIS FOR LOCALLY AVAILABLE ROV

The Forum Super Mohawk 36 ROV was procured to provide a site-dedicated, on-call, economical light work-class ROV option to HNEL, NAVY and WEC developers.

SEI has analyzed and compared costs of the Super Mohawk ROV and West Coast based ROVs with comparable capability. West Coast estimates are based on prior proposals SEI has compiled for work needed by the City and County of Honolulu in 240 foot seawater (fsw) on the south shore of Oahu. Work by the West Coast ROV was to be completed on SEI’s support vessel, “Huki Pau”.

Table 5-1 presents a cost comparison for anticipated ROV support work at WETS. Out of state fees do not include standby costs, due to weather delays. Standby fees typically cover the crew, per diem, hotels and some portion of the equipment. For ROV work, the crew is typically comprised of 3 people. Current per diem and hotel costs are \$177 and \$111 per person, respectively. SEI estimates that a minimum stand-by day cost for out of state crew and equipment may be roughly \$5,000 to \$7,000 per day.

As Table 5-1 presents, a comparable ROV supplied from outside of Hawaii would result in costs that would exceed reasonable testing budgets anticipated by WEC developers. The table shows that over a typical 3-year deployment period, a WEC installation would likely incur a minimum of \$2,653,030 more in support costs with an out-of-state based ROV than with the WETS Super Mohawk. Additionally, the fees listed in Table 6-1 do not include certain, and possibly sizeable standby fees that would be incurred due to unworkable sea conditions, unscheduled and emergency support, and the estimated 10 days of work that will be required to eventually decommission the site. The fee increases associated with not having the WETS Super Mohawk capability would likely be sufficiently large to kill the financial viability of most WEC testing programs.

Table 5-1 Cost Comparison of SEI Super Mohawk 36 ROV Against Out of State Option

	Out of State Equivalent ROV	SEI's Super Mohawk 36
Task 1: WETS Scheduled Inspections		
Mobilization and demobilization	\$ 220,000	\$ 25,000
Day rate	\$ 17,500	
Vessel cost	\$ 7,600	
2-Day Inspection Cost*	\$ 275,200	\$ 50,000
Subtotal Cost for 12 Inspections.	\$ 3,302,400	\$600,000
Task 2: WETS Deepwater Berth Repair Support		
Mobilization and demobilization	\$ 220,000	\$ 17,720
Day rate	\$17,500	\$ 16,850
Vessel cost	\$ 0	\$ 0
Subtotal Cost Deepwater Berth Repair Based on 5-day Operation	\$ 307,500	\$ 101,970
Task 3: OE Umbilical Retrieval from Seafloor		
Mobilization and demobilization	\$ 220,000	\$25,000
Day rate	\$ 17,500	
Vessel cost	\$ 7,600	
Subtotal Cost OE Umbilical Support	\$245,100	\$ 25,000
Purchase price of ROV	\$ 0	\$ 475,000
Total Cost for Scheduled Operations	\$ 3,855,000	\$ 1,201,970

*Inspection efforts are possible with lesser capable vehicles which would reduce the out of state scheduled inspection costs. However, a comparable vehicle was estimated to identify what costs would be for comparable remote operated vehicles over several WETS tasks.

6 SUMMARY

The Super Mohawk ROV is operational. It can currently be utilized from SEI's vessel, *Huki Pau* or another vessel of opportunity should the need at WETS arise. Once shipbuilding on SEI's site dedicated vessel, *Kūpa'a* are complete, scheduled for late 2018, the Super Mohawk ROV will be loaded and tested on-board the WETS dedicated vessel.

The addition of the Super Mohawk 36 to SEI provides HNEL, the U.S Navy and WEC developers with a competitive, readily available, local light work class ROV to support scheduled as well as unscheduled events at WETS through the sites projected timeframe.

While scheduled inspections at WETS can be conducted with smaller, lesser capable vehicles, the Forum SuperMohawk 36 will provide added benefit of high resolution video and better capability in the moderate to strong current encountered at WETS.

As the economic assessment highlighted, more complex operations that will require work class ROV support are significantly more economical with the procurement of SEI's Super Mohawk 36. Critical task efforts that require the capabilities of a work class ROV will have a significantly reduced mobilization and demobilization rate and no standby costs due to weather or project delays. These benefits are further realized when the Super Mohawk 36 is utilized onboard SEI's Site Dedicated Vessel, '*Kūpa'a*', when no significant ROV mobilization and demobilization is required.

APPENDIX I: ROV REQUIREMENTS REPORT

University of Hawaii Office of Research Services: Asia-Pacific Research Initiative for Sustainable Energy Systems 2012

**Wave Energy Testing
Task 001: Requirement Assessment**

Kaneohe Marine Corps Base, Oahu, Hawaii



Prepared for:

University of Hawaii Office of Research Services:
Asia-Pacific Research Initiative for Sustainable
Energy Systems 2012

Prepared by:

Sea Engineering, Inc.
863 N. Nimitz Hwy
Honolulu, HI 96817

Job No. 14191



Table of Contents

1. INTRODUCTION	3
2. PROJECT LOCATION	4
3. REQUIREMENT ASSESSMENT.....	5
FIGURE 1. KANEOHE MARINE CORPS BASE HAWAII – WAVE ENERGY TEST SITE.....	4

1. INTRODUCTION

In support of the University of Hawaii's Project "Asia-Pacific Research Initiative for Sustainable Energy Systems 2012 (APRISES12), Task 4.2, "Wave Energy Testing", Sea Engineering Inc. was contracted to assess remotely operated vehicle (ROV) requirements at the U.S. Navy Wave Energy Test Site (WETS); conduct a market study of available ROV options; purchase an ROV to support University of Hawaii, Department of Energy, and US Navy Research objectives at WETS; and, through use of the ROV, conduct an analysis of the utility and limitations of that ROV in support of wave energy test objectives.

The ROV will provide important research, maintenance and emergency response capabilities that are expected to greatly enhance the ability of the DOE and Navy at WETS.

Tasks under the Agreement for Services include:

- Task 0001: Requirements Assessment
- Task 0002: Market Study of Available ROVs
- Task 0003: ROV Procedural Analysis
- Task 0004: ROV Purchase
- Task 0005: ROV Installation Aboard Site-Dedicated Support Vessel
- Task 0006: ROV Operational Assessments and Final Report

This report presents the results of Task 0001 – Requirements Assessment.

2. PROJECT LOCATION

ROV operations will occur at the Kaneohe Marine Corps Base (MCBH) Wave Energy Test Site (WETS). The Wave Energy Test Site is located on the windward side of the Island of Oahu, offshore of the Kaneohe Marine Corps Base Hawaii. The test site is located northeast of Heeia Kea Small Boat Harbor within the security zone of MCBH. Key features of WETS, including the 30-meter test site, deepwater wave energy test sites (comprised of 60 meter and 80 meter berths), Heeia Kea Small Boat Harbor, Dedicated Vessel Approved Mooring Area, Pyramid Rock, Battery French and the MCBH Fuel Pier, are shown in Figure 1.

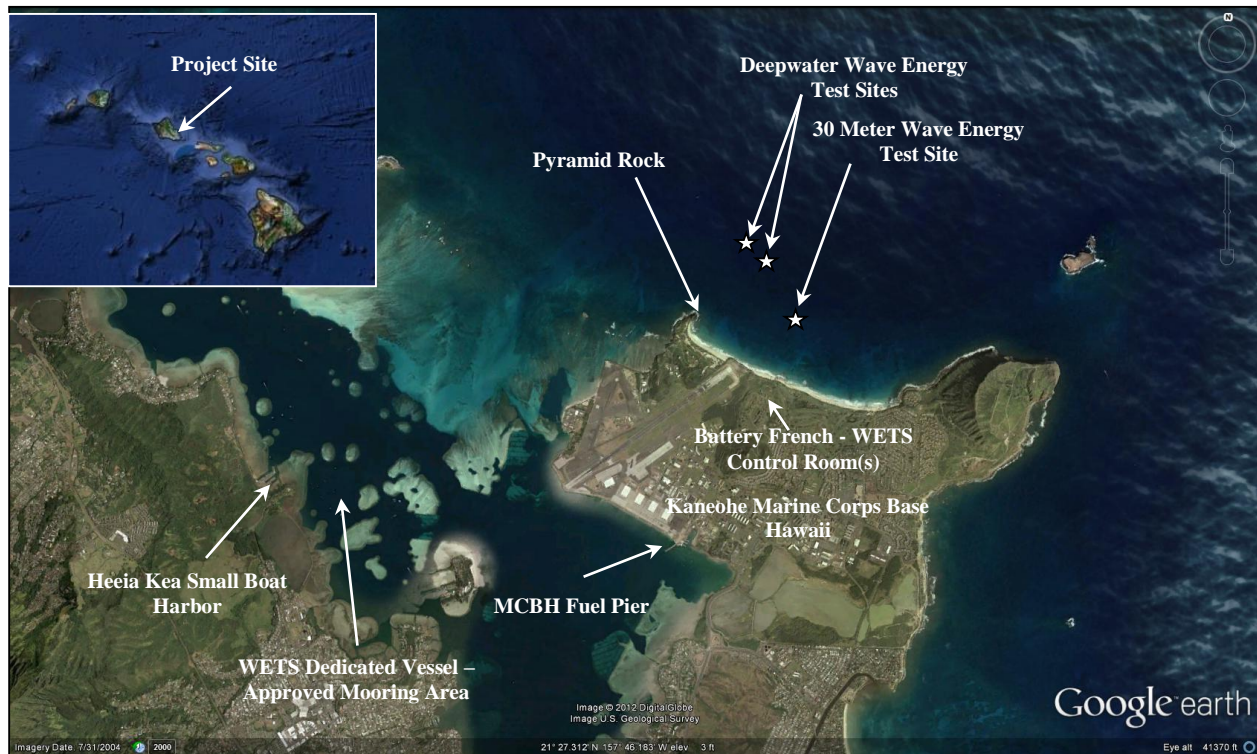

Figure 1. Kaneohe Marine Corps Base Hawaii – U.S. Navy Wave Energy Test Site

3. REQUIREMENT ASSESSMENT

Sea Engineering, Inc. has been conducting marine operations and engineering investigations at WETS since it was first established in 2001 for the testing of the first generation Ocean Power Technology wave energy buoy. Since that time, SEI has provided primary installation, maintenance, and engineering support for 5 different Wave Energy Conversion (WEC) devices. Specific work has included:

Engineering Support:

- Multibeam Surveys
- Sub-bottom Surveys
- Sidescan Sonar Surveys
- Sediment coring
- Geophysical Diver Surveys
- Ecological Surveys
- Diver Inspections of Mooring Hardware and WEC Device Components
- ROV Inspection Surveys of Mooring Hardware and WEC Device Components
- Sediment Transport Studies

Marine Operations and Commercial Diving Support:

- On-Shore Fabrication and Engineering Support for WEC Device Developers
- Logistics and Planning Associated with WEC Device Deployment and Recovery Operations
- Dive Support Vessels and Commercial Diver Crews to Support Installation, Recovery and Maintenance of WEC Devices
- Shore-End Cable Installation
- Cable Stabilization

Until 2014, the majority of work tasks and all diver tasks were conducted at the 30m test berth. At this location, all buoy and anchor components are readily accessible to divers using standard air diving techniques. Work at the 30m berth supported maintenance and inspection operations including visual and video recorded inspections, rigging for crane recovery of equipment, and when possible, underwater repairs for WEC device components. In 2014-2015, WETS was expanded to include 60m and 80m test berths capable of accommodating larger WECs. Per USACE EM385-1-1 Surface Supplied Air diving regulations, dive operations shall not be conducted at depths greater than 190 ft (57.9 meters), which is shallower than the anchor structures at the deepwater berths at WETS. At depths over 190ft, diving must be conducted using Mixed-Gas Diving Operations, which are not available on-island. Further, USACE EM385-1-1 mandates that whenever possible, diving shall not be used as a work method if the work objective can more safely and efficiently be accomplished by another means, including, but not limited to, Remotely Operated Vehicles (ROV).

In addition to the work completed at WETS, SEI managed the decommissioning of Ocean Powers Technology's Reedsport, Oregon Test Site in 2013 and 2014. This work included salvage and removal operations of a sunken sub-surface float, all mooring lines and floating gravitational base anchor in 240 feet of water. The sub-surface float and mooring lines were rigged and cut using a SAAB Cougar, light-workclass ROV.

Based on the work previously conducted at the shallow berth at WETS and the deepwater site in Oregon, and close consultation with NAVFAC and HNEI regarding expected WEC device deployments and other operations in the coming years at the WETS deep berths, Sea Engineering, Inc. anticipates that the following activities requiring the use of an ROV may be encountered at the Navy Wave Energy Test Site.

- High Resolution Video Inspection of Mooring Hardware, cables to shore, and deployed WEC Devices
- High Resolution Ecological Surveys at Deepwater Berths
- Ultrasonic Thickness Measurements of Mooring or WEC Device Hardware
- Maintenance and Salvage Support
 - Rigging Assistance
 - Shackle and Chain Cutting
 - Hawser Cutting
- Diver Assistance
- Site Decommissioning Assistance

Depths at WETS require that the vehicle be capable of operating in up to 150 meters water depth and work in moderate currents while being able to assist in line, chain and shackle cutting and rigging operations as well as those associated with inspection support.

4. WETS REQUIREMENTS

Based on the requirements assessment above, the ROV should be capable of hosting a high definition video capability that will allow high-resolution analysis of subsea components exposed to corrosion, biofouling and motion-related wear. Additionally, routine and unexpected maintenance tasks will require that the ROV be outfitted with a versatile manipulator arm that can be outfitted with a range of tools, such as cable cutters, cleaning tools, a water jet, rotary disc cutter, large line cutter, cathodic protection probe and ultrasonic thickness gauge. Ideally, the ROV would be capable of interchanging multiple tools within an operation or dual manipulators for flexibility.

HNEI envisions that specific actions at WETS that may require the use of a well-tooled ROV for cutting of shackles, chain or large diameter rope and the rigging of straps and crane hooks for hardware and equipment recovery. As such, minimum ROV capabilities were determined to include the following.

Minimum single 5-way manipulator capable of the following tasks:

- Rigging Assistance

- Line Cutting

- Recovery Capabilities

High Resolution Video Camera(s)

Additional Tooling Capabilities

- Grinding Disc

- Ultrasonic Thickness Gauge

- Cathodic Potential Gauge

The ROV Market Study will examine these requirements in light of what vehicles are available on the market as of early 2016, and will conclude with a recommendation for purchase to HNEI.

APPENDIX II: MARKET STUDY REPORT

University of Hawaii Office of Research Services: Asia-Pacific Research Initiative for Sustainable Energy Systems 2012

**Wave Energy Testing
Task 002: Market Study of Available ROVs**

Kaneohe Marine Corps Base, Oahu, Hawaii



Prepared for:

University of Hawaii Office of Research Services:
Asia-Pacific Research Initiative for Sustainable
Energy Systems 2012

Prepared by:

Sea Engineering, Inc.
863 N. Nimitz Hwy
Honolulu, HI 966817
Job No. 13001



Table of Contents

1. INTRODUCTION	3
2. PROJECT LOCATION	4
3. MARKET STUDY OF ROVS	5
4. ROV MARKET.....	6
5. ROV SELECTION	7
5.1 FINAL ROV SELECTION	7
FIGURE 1. KANEHOHE MARINE CORPS BASE HAWAII – WAVE ENERGY TEST SITE.....	4

1. INTRODUCTION

In support of the University of Hawaii's Project "Asia-Pacific Research Initiative for Sustainable Energy Systems 2012 (APRISES12), Task 4.2, "Wave Energy Testing", Sea Engineering Inc. (SEI) was contracted to assess remotely operated vehicle (ROV) requirements at the U.S. Navy Wave Energy Test Site (WETS), conduct a market study of available ROV solutions, purchase an ROV to support University of Hawaii, Department of Energy, and US Navy Research objectives at WETS, and, through use of the ROV, to conduct an analysis of the utility and limitations of that ROV in support of wave energy test objectives.

The ROV will provide important research, maintenance and emergency response capabilities that are expected to greatly enhance the ability of the DOE and Navy at WETS.

Tasks under the Agreement for Services include:

- Task 0001: Requirements Assessment
- Task 0002: Market Study of Available ROVs
- Task 0003: ROV Procedural Analysis
- Task 0004: ROV Purchase
- Task 0005: ROV Installation Aboard Site-Dedicated Support Vessel
- Task 0006: ROV Operational Assessments and Final Report

This report presents the results of Task 0002 – Market Study of Available ROVs.

2. PROJECT LOCATION

ROV studies and operations are based on work anticipated at the Kaneohe Marine Corps Base (MCBH) Wave Energy Test Site (WETS). The Wave Energy Test Site is located on the windward side of the Island of Oahu, offshore of the Kaneohe Marine Corps Base Hawaii. The test site is located northeast of Heeia Kea Small Boat Harbor within the security zone of MCBH. Key features at WETS, including The 30-meter test site, deepwater wave energy test sites (comprised of 60 meter and 80 meter berths), Heeia Kea Small Boat Harbor, Dedicated Vessel Approved Mooring Area, Pyramid Rock, Battery French and the MCBH Fuel Pier, are shown in Figure 1.

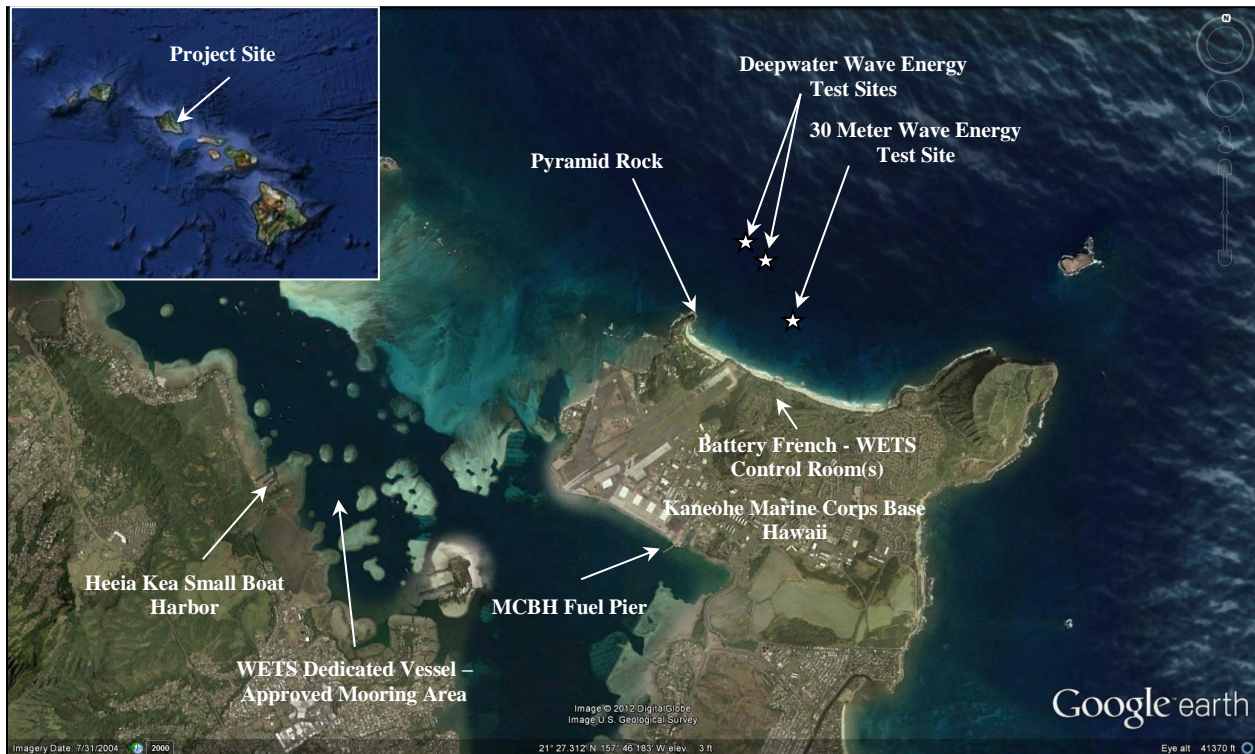

Figure 1. Kaneohe Marine Corps Base Hawaii – Wave Energy Test Site

3. MARKET STUDY OF ROVS

Expected work tasks for Remote Operated Vehicles at WETS were defined in Sea Engineering's "University of Hawaii Office of Research Services: Asia-Pacific Research Initiative for Sustainable Energy Systems 2012. Wave Energy Testing, Task 001: Requirement Assessment". Briefly, this work is expected to include:

- High Resolution Video Inspection of Mooring Hardware and WEC Devices
- High Resolution Ecological Surveys at Deepwater Berths
- Ultrasonic Thickness Measurements of Mooring or WEC Device Hardware
- Maintenance and Salvage Support
 - Rigging Assistance
 - Shackle and Chain Cutting
 - Hauser Cutting
- Diver Assist
- Site Decommissioning Assistance

Based on the requirements assessment, the ROV should be capable of hosting a high definition video capability that will allow high-resolution analysis of subsea components exposed to corrosion, biofouling and motion-related wear. Additionally, routine and unexpected maintenance tasks will require that the ROV be outfitted with a versatile manipulator arm that can be outfitted with a range of tools, such as cable cutters, cleaning tools, a water jet, rotary disc cutter, large line cutter, cathodic protection probe and ultrasonic thickness gauge. Ideally, the ROV would be capable of interchanging multiple tools within an operation or dual manipulators for flexibility.

HNEI envisions that specific actions at WETS that may require the use of a well-tooled ROV for cutting of shackles, chain or large diameter rope and the rigging of straps and crane hooks for hardware and equipment recovery. As such, minimum ROV capabilities were determined to include the following.

- Minimum single 5-way manipulator capable of the following tasks:
 - Rigging Assistance
 - Line Cutting
 - Recovery Capabilities
- High Resolution Video Camera(s)
- Additional Tooling Capabilities
 - Grinding Disc
 - Ultrasonic Thickness Gauge
 - Cathodic Potential Gauge
- Capability to Work in 100 Meter Water depth
- Capability to Operate in Currents experienced at WETS and around the Hawaiian Islands, anticipated to be less than or equal to 2 knots.

4. ROV MARKET

The ROV market is comprised of Inspection Class, Light Workclass, Medium Workclass, and Heavy Workclass. A fifth class, inspection/light work class is also available, and is typically comprised of vehicles in the Light Workclass category, which are available with high definition video resolution.

The requirements outlined in the previous section, notably the 5-way manipulator, line cutting and the additional tooling capabilities, require a ROV in the light work class category.

The inspection/light workclass category includes the following manufacturers:

- 1) Ageotec (<http://www.ageotec.com/en/rov-en/rov-perseo-gtv/>)
- 2) SAAB Seaeye (<http://www.seaeye.com/cougar-xti.html>)
- 3) SMD (<http://www.smd.co.uk/products/work-class-rov-systems/list.htm>)
- 4) Forum Sub-Atlantic (http://www.f-e-t.com/our_products_technologies/subsea-solutions/rovs-observation/)
- 5) TMT (<http://www.tmtrov.com.au/rovs/navigator>)
- 6) ISE (<http://www.ise.bc.ca/rov.html>)
- 7) Submersible Systems (<http://ssirovs.com/index.php/rov/trv-hd.html>)
- 8) ROVTECH (<http://www.rovtechsolutions.co.uk/remotelyoperatedvehicles.php>)
- 9) Argus (<http://argus-rs.no/products/electrical-rovs/>)
- 10) DOER (<http://www.doermarine.com/>)
- 11) ECA (<http://www.ecagroup.com/en/activities/subsea-works>)

ROV operations, other than with inspection class ROVs, typically require large vessel support and typically support diver and larger salvage operations. Therefore, ROV durability and reliability are essential; unforeseen breakdowns and long-turnarounds on replacement parts and technical support can have substantial cost and schedule impacts.

Selection of an appropriate manufacturer is based largely on vehicle reliability, vehicle outfitting and capability, customer service, market maturity and market penetration. These criteria were evaluated based on information provided on the manufacturers websites, preliminary discussion with manufacturers and peer discussion with current vehicle users.

For additional technical input on ROV selection, Sea Engineering, Inc. consulted with Eric Crumpton, former Global Diving and Salvages ROV Operations Manager, who has been involved with ROV manufacturing and operations for over 20 years.

5. ROV SELECTION

Based on the criteria outlined above, market assessment and discussions and analysis with peers and Mr. Crumpton, SEI narrowed the field of potential ROV manufacturers to SAAB Seaeye, Forum Sub-Atlantic and AMD.

Specifically, the following vehicles from each manufacturer met the specifications outlined in Section 3.

AMD:

- ATOM (Inspection / Medium Work Class)

SAAB SEAEEYE:

- Seaeye Cougar-XT (Inspection / Work Light Work Class)
- Seaeye Cougar-XTi (Inspection / Work Light Work Class)
- Seaeye Panther-XT (Inspection / Work Light Work Class)
- Seaeye Panther-XTI (Inspection / Work Light Work Class)

SUB-ATLANTIC FORUM:

- Super Mohawk (Inspection / Work Light Work Class)
- Comanche (Inspection / Medium Work Class)

All vehicles mentioned above have sufficient depth ratings for use at WETS and are capable of providing high-resolution video imagery.

5.1 FINAL ROV SELECTION

Final selection of the WETS support ROV was narrowed to two all-electric vehicles, SAAB Seaeye Cougar and Forum Sub-Atlantic Super Mohawk. AMD Atom, SAAB Seaeye Panther and Sub-Atlantic Forum Comanche provided capabilities higher than those required for support operations at WETS. The increased capabilities result in increased vehicle size and costs.

With a stated goal of maintaining a site-dedicated vessel that could provide deepwater diving operations, WEC support operations (including umbilical installation and WEC device hookup) and ROV operations, SEI determined that the additional size of the larger, more capable vehicles would become a limitation in providing a flexible work platform for developers looking to complete multiple operations from one vessel. The more compact SAAB Cougar and Forum Sub-Atlantic Super Mohawk were thus selected as appropriate for WETS requirements. Specification sheets for both the SAAB Cougar and Forum Sub-Atlantic Super Mohawk are included in Appendix I.

Final ROV selection between the SAAB and Forum Sub-Atlantic was based on similar requirements outlined above, and peer feedback on durability and customer service.

Sea Engineering, Inc. discussions included the following:

Global Diving & Salvage (Eric Crumpton):

Vehicle Used: SAAB Cougar

Meridian Ocean Services:

Vehicle Used: Sub-Atlantic Super Mohawk and SAAB Cougar

Oceaneering:

Vehicle Used: Customized Sub-Atlantic Super Mohawk

Eclipse Group:

Vehicle Used: Sub-Atlantic Super Mohawk

Following this extensive peer review and detailed discussions with both manufacturers, a final selection for the Forum Sub-Atlantic Super Mohawk was made. Final decision factors included:

- 1) Durability/Reliability – Both systems were given similar reviews by ROV users. However, the Sub-Atlantic was noted to use non-proprietary connectors and discussion with peers indicated a slightly shorter turn-around time on parts and components.
- 2) Price – While in-water capabilities for similar priced machines were equivalent, Forum Sub-Atlantic's user interface includes an advanced diagnostics system, which actively monitors the condition and health of key components, including the thrusters and manipulators. This capability allows the user to replace components before catastrophic failures. This was also an option on the SAAB vehicle, but required a custom built SAAB Cougar with costs for both the vehicle, and spare parts, significantly higher than a comparable Forum Sub-Atlantic Super Mohawk. SEI was able to acquire a larger spares kit with the Forum Sub-Atlantic as well, ensuring a better end product for the MCBH Wave Energy Test Site.
- 3) Peer Review – Overall peer review from companies operating the SAAB Cougar and Forum Sub-Atlantic ROV's indicated a preference for the Forum Sub-Atlantic System.

For these reasons, Sea Engineering, Inc. has selected, and initiated the purchase of, the Forum Sub-Atlantic Super Mohawk ROV for support at the MCBH Wave Energy Test Site.

APPENDIX III: ROV PROCEDURAL ANALYSIS

University of Hawaii Office of Research Services: Asia-Pacific Research Initiative for Sustainable Energy Systems 2012

**Wave Energy Testing
Task 003: ROV Procedural Analysis**

Kaneohe Marine Corps Base, Oahu, Hawaii



Prepared for:

University of Hawaii Office of Research Services:
Asia-Pacific Research Initiative for Sustainable
Energy Systems 2012

Prepared by:

Sea Engineering, Inc.
863 N. Nimitz Hwy
Honolulu, HI 966817
Job No. 13001



Table of Contents

1. INTRODUCTION	3
2. PROJECT LOCATION	4
3. SUPER MOHAWK WORK VAN AND VESSEL SETUP	5
3.1 KUPA’A DECK LAYOUT.....	5
3.2 SUPER MOHAWK CONTROL VAN	7
4. DEPLOYMENT AND RECOVERY OF SUPER MOHAWK ROV	11
4.1 ROV OPERATIONS	12
4.1.1 ROV OPERATIONS.....	12
FIGURE 1. KANEHOHE MARINE CORPS BASE HAWAII – WAVE ENERGY TEST SITE.....	4
FIGURE 3: DEDICATED SITE VESSEL – DECK LAYOUT FOR ROV OPERATIONS	6
FIGURE 4: SEI ROV CONTROL VAN – GENERAL LAYOUT	8
FIGURE 5: SEI ROV CONTROL VAN – ROV CONSOLE AND CONTROLS LAYOUT.....	9
FIGURE 6: SEI ROV CONTROL VAN – CONTROL VAN CUTAWAY	10
FIGURE 6: EXAMPLE OF RUNNING LOCK-LATCH.....	11

1. INTRODUCTION

In support of the University of Hawaii’s Project “Asia-Pacific Research Initiative for Sustainable Energy Systems 2012 (APRISES12), Task 4.2, “Wave Energy Testing”, Sea Engineering Inc. (SEI) was contracted to assess remotely operated vehicle (ROV) requirements at the U.S. Navy Wave Energy Test Site (WETS), conduct a market study of available ROV solutions, purchase an ROV to support University of Hawaii, Department of Energy, and US Navy Research objectives at WETS, and, through use of the ROV, to conduct an analysis of the utility and limitations of that ROV in support of wave energy test objectives.

The ROV will provide important research, maintenance and emergency response capabilities that are expected to greatly enhance the ability of the DOE and Navy at WETS.

Tasks under the Agreement for Services include:

- Task 001: Requirements Assessment
- Task 002: Market Study of Available ROVs
- Task 003: ROV Procedural Analysis
- Task 004: ROV Purchase
- Task 005: ROV Installation Aboard Site-Dedicated Support Vessel
- Task 006: ROV Operational Assessments and Final Report

This report presents the results of Task 003 – ROV Procedural Analysis

2. PROJECT LOCATION

ROV studies and operations are based on work anticipated at the Kaneohe Marine Corps Base (MCBH) Wave Energy Test Site (WETS). The Wave Energy Test Site is located on the windward side of the Island of Oahu, offshore of the Kaneohe Marine Corps Base Hawaii. The test site is located northeast of Heeia Kea Small Boat Harbor within the security zone of MCBH. Key features at WETS, including the 30-meter test site, deep water wave energy test sites (comprised of 60 meter and 80 meter berths), Heeia Kea Small Boat Harbor, Dedicated Vessel Approved Mooring Area, Pyramid Rock, Battery French and the MCBH Fuel Pier, are shown in Figure 1.

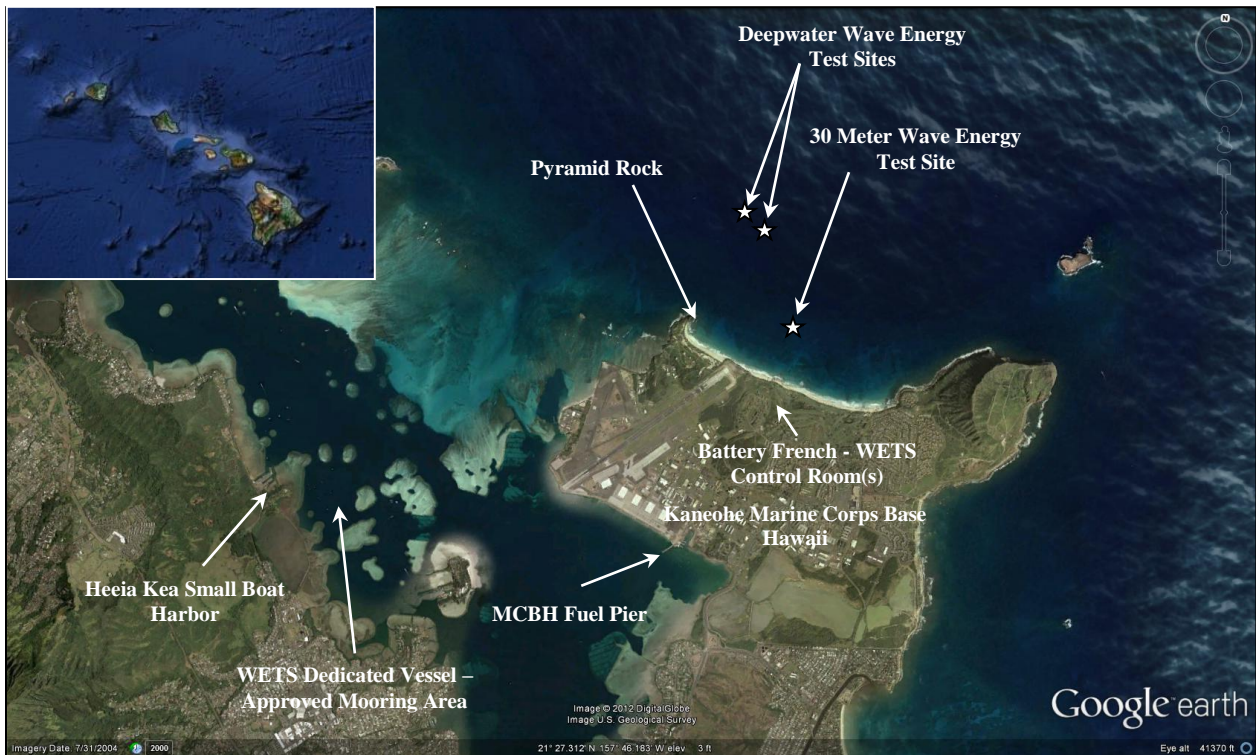

Figure 1. Kaneohe Marine Corps Base Hawaii – Wave Energy Test Site

3. SUPER MOHAWK WORK VAN AND VESSEL SETUP

The Forum Sub-Atlantic Super Mohawk ROV operations will be supported from the WETS site vessel, which will house the ROV control van and provide power and crane or A-frame support for the operations.

The Super Mohawk ROV will be free-swimming, meaning the vehicle will not be tethered to a recovery winch. The vehicle will be deployed, either from the stern of the vessel, using an A-frame or from the side of the vessel using a deck mounted crane.

ROV control operations will be conducted from a 20-ft Conex, noted as a Control Van, secured on-deck of the WETS dedicated site vessel, *Kupa 'a*.

Both deployment of the ROV from the work vessel and the Control Van will be discussed in greater detail below.

3.1 *Kupa 'a* Deck Layout

The deck layout for the dedicated site vessel, *Kupa 'a*, is presented in Figure 2. The layout shows the vessel after modifications, including widening of the hull by 8 ft to 26'-7.5" as well as addition of the deck crane, 4-point anchor system and A-frame.

The control van will be located forward on the stern deck, leaving working space stern of the control van for ROV deployment and recovery operations as well as space for recovery of equipment or hardware associated with operations at the WETS site.

3.2 Super Mohawk Control Van

The Super Mohawk will be operated from a control van, secured and located forward on the stern deck of WETS dedicated site vessel.

The control van is organized such that 70% of the space is dedicated for operations and 30% as a maintenance shop, respectively. The general layout of the control van is shown in Figure 3. The van is shown with the maintenance work shop on the left of the figure and the operations room on the right.

The operations room layout is presented in Figure 4. General equipment will include:

- ROV Rack with Control Boards and ROV Control Hardware
- 32” High Definition Camera Monitor for HD Camera
- 19” Standard Definition Camera Monitor for SD Camera
- 19” Standard Definition Camera Monitor for Rear Camera
- Control Monitor Touch Screen
- 19” Monitor and Laptop for Hypack Navigation Display and Integration with Applied Acoustics Ultra Short Baseline (USBL) EasyTrack Lite positioning system
- Two Videosoft Computers and Hard drives for recording video feeds from ROV
- Communications to Boat Captain, and Deck for Tether and Vessel Management

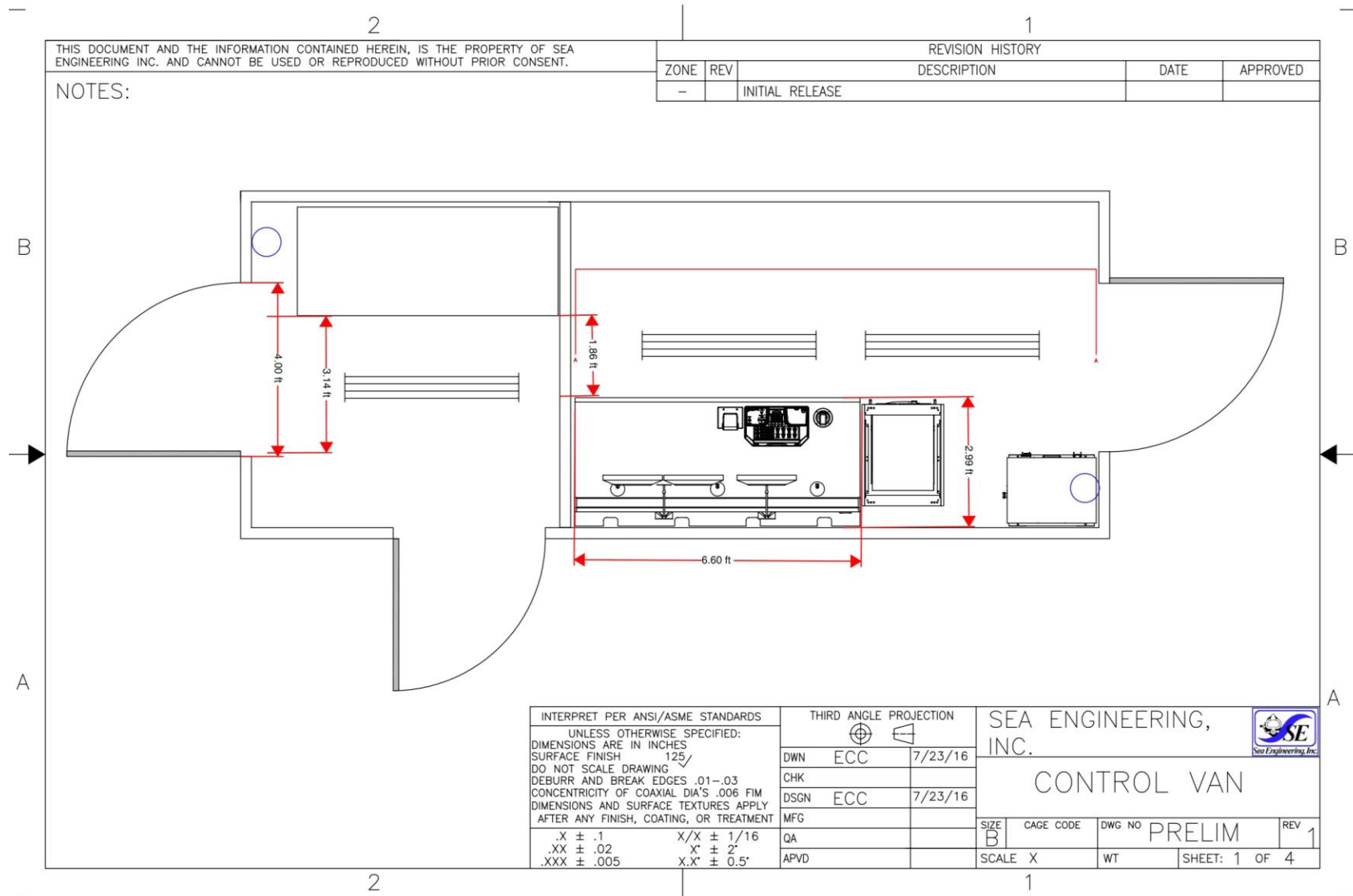

Figure 3: SEI ROV Control Van – General Layout

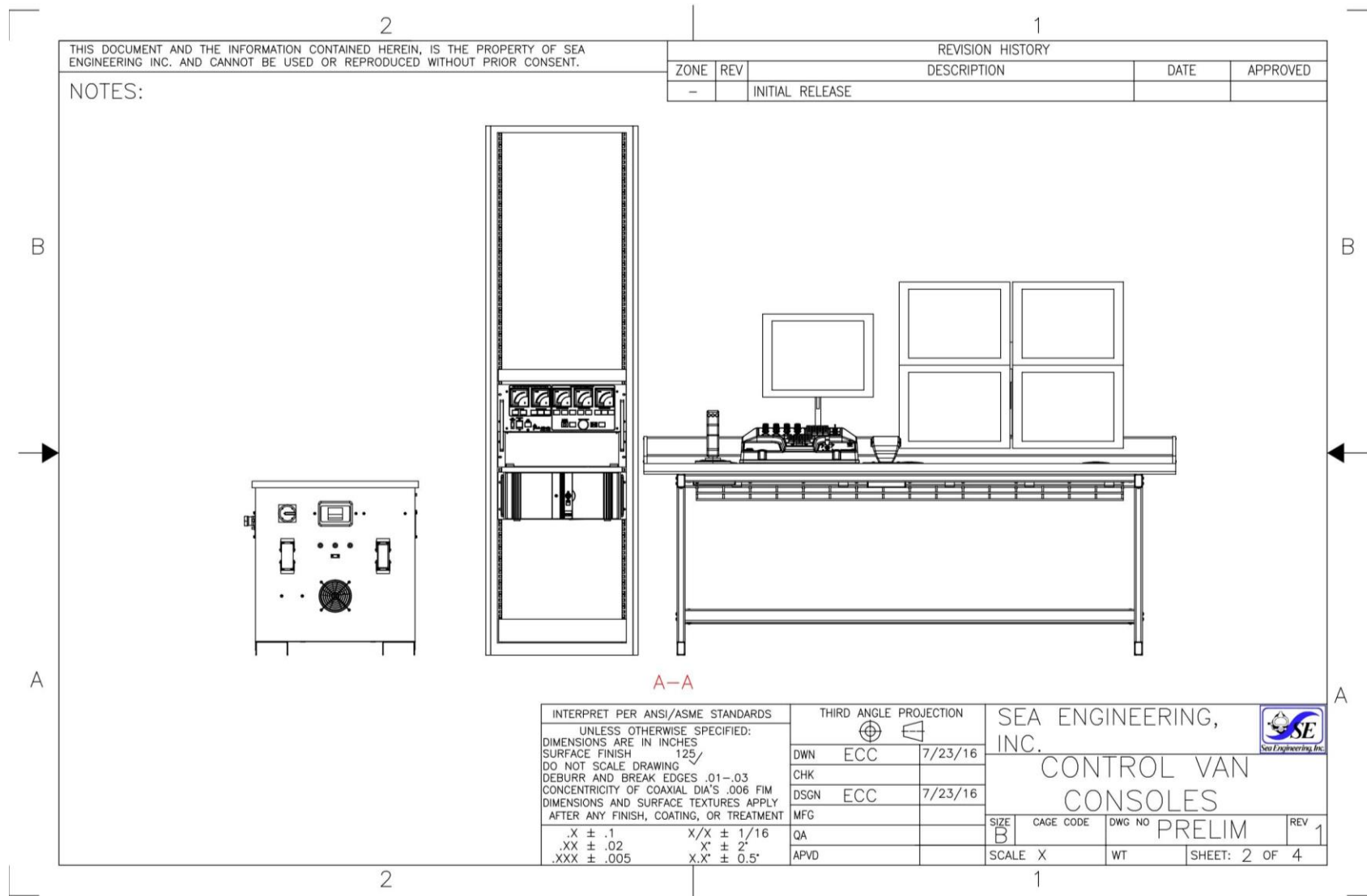

Figure 4: SEI ROV Control Van – ROV Console and Controls Layout

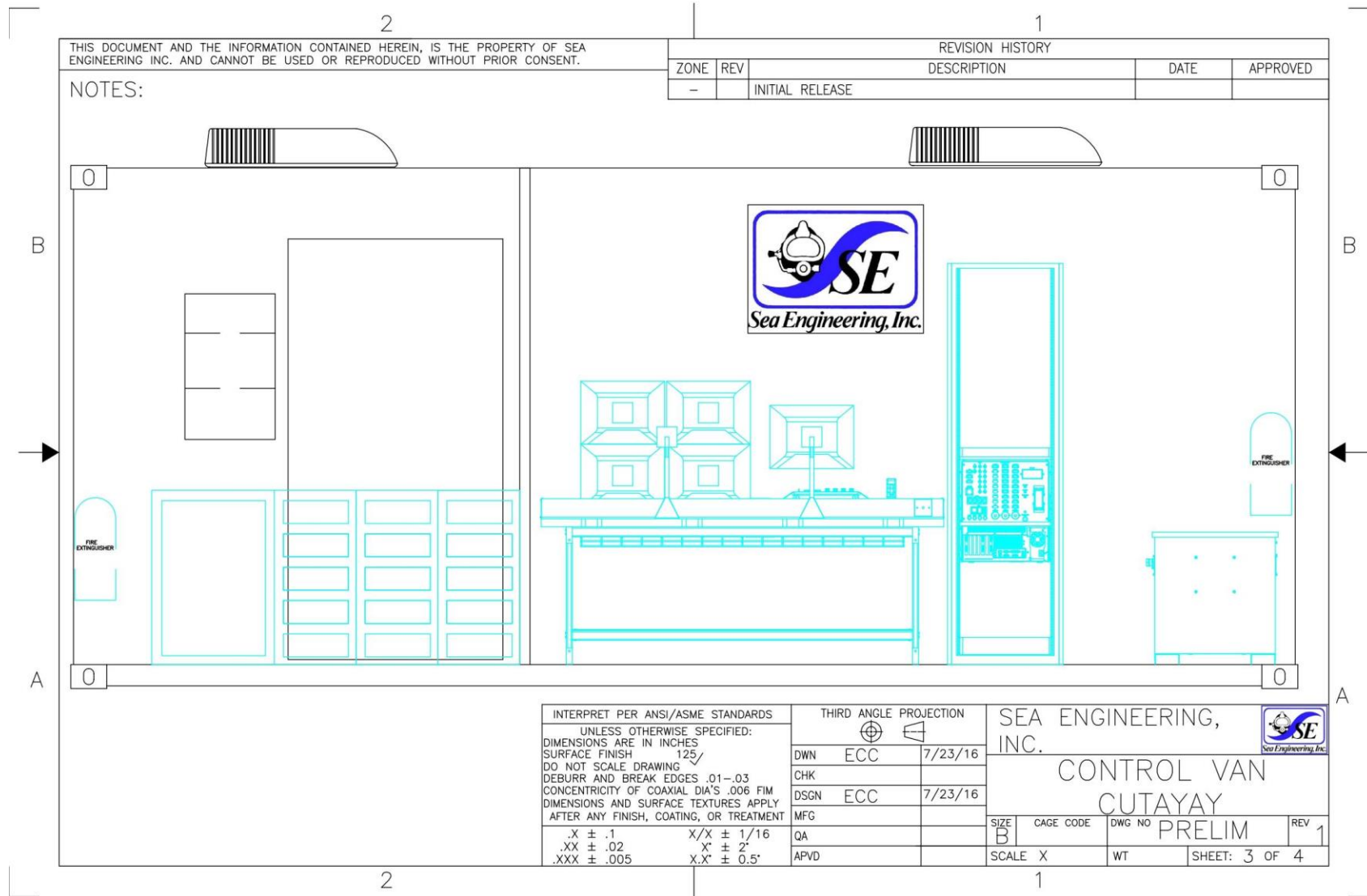

Figure 5: SEI ROV Control Van – Control Van Cutaway

4. DEPLOYMENT AND RECOVERY OF SUPER MOHAWK ROV

The deployment and recovery of the super mohawk ROV will utilize an Imenco ROV latch. The latch has a safe working load of 1.5 tons and is designed in accordance with “DNV Rules for Certification of Lifting Appliances”.

The running latch-lock system, an example of which is shown in Figure 6, works by securing around the ROV umbilical and being attached to the crane or A-frame winch line.

During deployments, the latch-lock is secured to the ROV and the A-frame is used to lift and place the ROV overboard of the vessel. Once the ROV is in the water, and the ROV systems check-out is complete, the latch-lock is released, using the latch-lock release line, and recovered to the vessel. Once released, the ROV is free to swim and descend as needed, with deck-side crew tending the umbilical off the vessel.

During recovery operations, the ROV is driven back to the vessel, while deck-side crew manage the slack umbilical and recover it on-deck. Once near surface, the latch-lock is placed around the ROV umbilical and lowered down to the ROV. Upon contact with the ROV, the latch-lock will latch onto the ROV, securing it to the A-frame winch line. The ROV will then be recovered on-deck and operations secured.

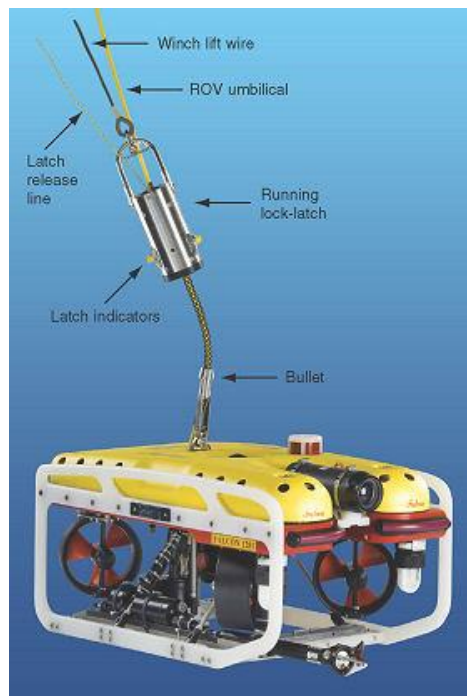

Figure 6: Example of Running Lock-Latch

4.1 ROV Operations

ROV operations from the dedicated site vessel will consist of a minimum 4-man crew, comprised of the ROV Pilot, ROV Co-Pilot, Deckhand / Assistant Navigator and Boat Captain. The Boat Captain and Deckhand will be responsible for getting the vessel and crew to location and secured on-site. Once the vessel is anchored, the ROV Pilot, Co-Pilot and Deckhand will complete ROV system checks and begin preparing the vehicle for deployment from the vessel. The deckhand will be responsible for tending the umbilical during launch and recovery as well as general support as directed during operations. When conditions require, a navigator may be added to the crew to provide additional support in low-visibility or operations which have increased risk of entanglement of the vehicle.

General deployment and recovery procedures for ROV operations are outlined below. The detailed manual for the Forum Super Mohawk is included in Appendix I.

4.1.1 ROV OPERATIONS

Task 1: Vessel Secured On-Site. This includes 4-point anchoring, and shutting down the main engines.

- a) Captain will inform ROV crew that vessel is secured and main engines are shut-down.
- b) Boat crew will activate hydraulic deck crane, A-frame, and deck winch in preparation for ROV deployment.

Task 2: ROV crew unlatch ROV from storage in ROV control van and begin hooking up power for electronics in control room.

- a) Captain to maintain supervision of vessel and 4-point anchoring.
- b) Deckhand to assist with unlatching ROV from control van and prepare lifting strap for lifting the ROV from the control van.
- c) ROV crew to finalize power hookups
 - i) Power for the ROV will come from the Caterpillar gensets in the main engine room, rated at 100kW each.

Task 3: Using the vessel deck crane, recover ROV from conex workshop and locate on stern of vessel.

- a) While ROV crew continues preparation of ROV in the conex, Captain and Deckhand to lift ROV out of control van and onto the stern under the A-frame.

Task 4: ROV crew begin system check-out and preparations for deployment per the Forum Sub-Atlantic Super Mohawk Manual, provided in Appendix I.

Task 5: Once topside preparations are complete, use the lock-latch system, in conjunction with the A-frame to lift and lower the ROV over the stern of the vessel and into the water. During deployment into the water, a minimum of 2 tag lines should be used to stabilize the vehicle during the lift.

Task 6: ROV crew to complete in-water system check-out and final preparations for dive operations according to the Forum Sub-Atlantic Super Mohawk Manual, provided in Appendix I.

Task 7: Conduct ROV operations

Task 8: Upon completion of ROV operations. ROV is maneuvered back to the stern of the support vessel.

- Captain and deckhand to prepare A-frame and latch-lock mechanism for recovery.

Task 9: When the ROV is at a depth of 10 feet, crew releases latch-lock mechanism.

Task 10: Once latch-lock has made connection with the ROV, Captain begins crane operations to recover ROV.

Task 11: ROV secured on-deck. ROV crew to begin system shutdown operations and wash-down vehicle and equipment.

Task 12: Support vessel breaks moorage, recovers anchors and makes way for port.

APPENDIX IV: REPORT OF ROV PURCHASE

University of Hawaii Office of Research Services: Asia-Pacific Research Initiative for Sustainable Energy Systems 2012

**Wave Energy Testing
Task 004: ROV Purchase**

Kaneohe Marine Corps Base, Oahu, Hawaii



Prepared for:

University of Hawaii Office of Research Services:
Asia-Pacific Research Initiative for Sustainable
Energy Systems 2012

Prepared by:

Sea Engineering, Inc.
863 N. Nimitz Hwy
Honolulu, HI 966817
Job No. 13001



Table of Contents

1. INTRODUCTION	3
2. PROJECT LOCATION	4
3. PROJECT BACKGROUND.....	5
4. ROV PURCHASE.....	6
FIGURE 1. KANEOHE MARINE CORPS BASE HAWAII – WAVE ENERGY TEST SITE.....	4

1. INTRODUCTION

In support of the University of Hawaii’s Project “Asia-Pacific Research Initiative for Sustainable Energy Systems 2012 (APRISES12), Task 4.2, “Wave Energy Testing”, Sea Engineering Inc. (SEI) was contracted to assess remotely operated vehicle (ROV) requirements at the U.S. Navy Wave Energy Test Site (WETS), conduct a market study of available ROV solutions, purchase an ROV to support University of Hawaii, Department of Energy, and US Navy Research objectives at WETS, and conduct an analysis of the utility and limitations of that ROV in support of wave energy test objectives.

The ROV will provide important research, maintenance and emergency response capabilities that are expected to greatly enhance the ability of the DOE and Navy at WETS.

Tasks under the Agreement for Services include:

- Task 001: Requirements Assessment
- Task 002: Market Study of Available ROVs
- Task 003: ROV Procedural Analysis
- Task 004: ROV Purchase
- Task 005: ROV Installation Aboard Site-Dedicated Support Vessel
- Task 006: ROV Operational Assessments and Final Report

This report presents the results of Task 0004 – ROV Purchase.

2. PROJECT LOCATION

ROV studies and operations are based on work anticipated at the Kaneohe Marine Corps Base (MCBH) Wave Energy Test Site (WETS). The Wave Energy Test Site is located on the windward side of the Island of Oahu, offshore of the Kaneohe Marine Corps Base Hawaii. The test site is located northeast of Heeia Kea Small Boat Harbor within the security zone of MCBH.

Key features at WETS, including The 30-meter test site, deepwater wave energy test sites (comprised of 60 meter and 80 meter berths), Heeia Kea Small Boat Harbor, Dedicated Vessel Approved Mooring Area, Pyramid Rock, Battery French and the MCBH Fuel Pier, are shown in

Figure 1.

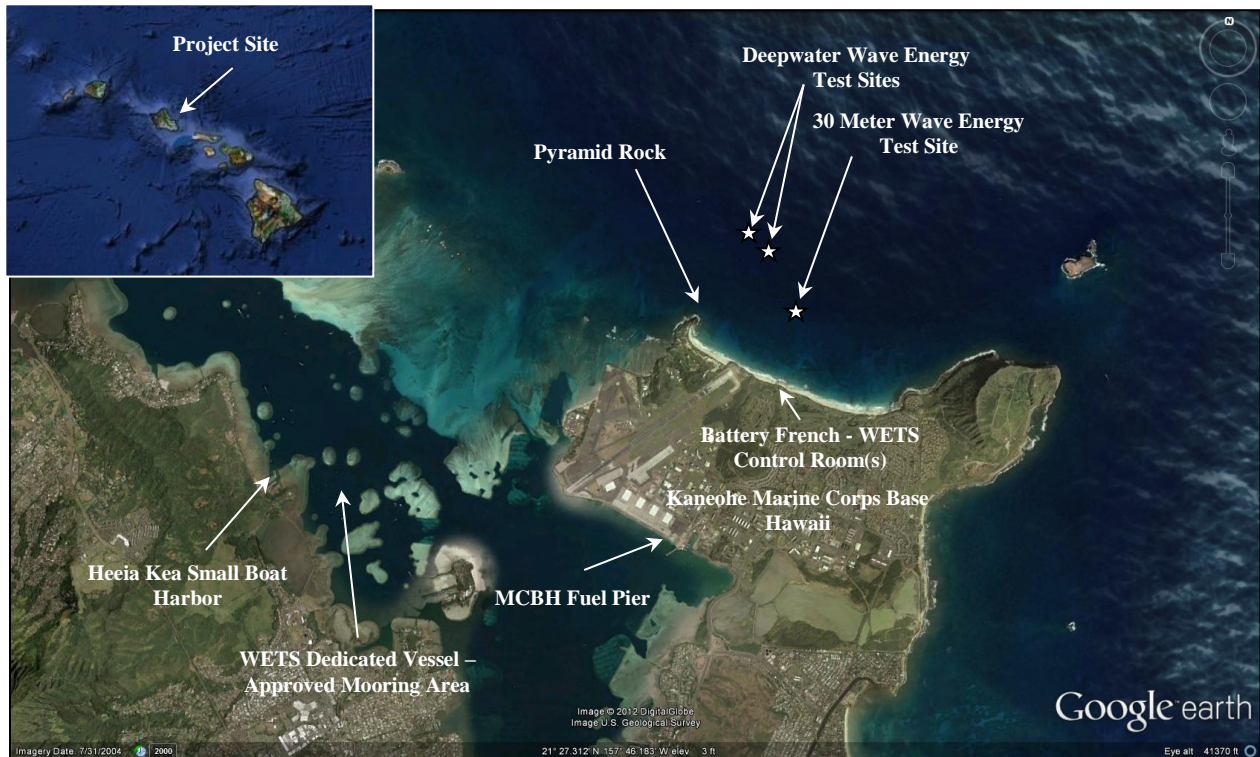

Figure 1. Kaneohe Marine Corps Base Hawaii – Wave Energy Test Site

3. PROJECT BACKGROUND

Prior to purchase of the Super Mohawk 36 ROV, SEI completed an assessment of remote operated vehicles requirements for MCBH Wave Energy Test Site, provided in the “Task -001: Requirement Assessment” report. The requirement assessment report highlighted that the expansion of the site to include two deepwater berths, at 60m and 80 m water depths, would require support beyond standard air-diving limits. This support work includes:

- High resolution video inspection of mooring hardware, cables to shore, and deployed WEC devices
- High resolution ecological surveys at deepwater berths
- Ultrasonic Thickness measurements of mooring or WEC device hardware
- Maintenance and salvage support
- Rigging assistance
- Shackle and chain cutting
- Hawser cutting
- Diver assistance
- Site decommissioning assistance

Based on these requirements, an ROV with the following minimum capabilities is required:

- Minimum single 5-way manipulator capable of the following tasks:
 - Rigging assistance
 - Line cutting
 - Recovery capabilities
- High resolution video camera(s)
- Additional tooling capabilities
 - Grinding disc
 - Ultrasonic thickness gauge
 - Cathodic potential gauge
- Capability to work in 100 meter water depth
- Capability to operate in currents experienced at WETS and around the Hawaiian Islands, anticipated to be less than or equal to 2 knots.

As a follow-on to “Task - 001: Requirement Assessment” report, SEI completed a market study of available ROV’s. The findings of the market study were included in “Task 002 – Market Study of Available ROVs”. Final ROV selection of the Forum Sub-Atlantic Super Mohawk 36, based on durability and reliability, price, and peer reviews was selected.

4. ROV PURCHASE

After selection of the Super Mohawk 36 ROV from Forum Sub-Atlantic, SEI entered into a contractual manufacturing agreement in March of 2016. Payments on the vehicle were made in 4 installments based on milestones of the ROV construction. These included (1) 25% Deposit Due On Contract Execution, (2) 25% on Frame Load Test, (3) 25% at Start of Vehicle Integration (4) 25% on Completion of Facility Acceptance Tests (FAT). Total purchase price, excluding spare parts, or the upgraded second controller for the manipulator arm totaled 467,332 GBP.

On April 4, 2016, SEI fixed an exchange rate of 1GBP to 1.43 USD to minimize long-term exposure to fluctuations in the market and provide a stable purchase price of the equipment. At the secured exchange rate, the USD purchase price for the Super Mohawk 36 ROV was \$673,875.

Per the subcontract agreement, SEI will invoice for the Not-to-Exceed amount of \$475,000. The remainder of the purchase price, spares cost, additional hand control for the second manipulator arm and on-site training for crew are cost shared by Sea Engineering, Inc.

The FAT and purchase invoices (in GBP) are attached as appendices to this document.

5. REMAINING WORK

Remaining work, as part of this contract, includes:

- Task 003: Procedural Analysis
- Task 005: ROV Installation Aboard Site-Dedicated Vessel
- Task 006a: Interim Operational Assessment #1
- Task 006b: Interim Operational Assessment #2
- Task 006c: Final Report

5.1 Task 003 – Procedural Analysis

Sea Engineering has completed a draft of the procedural analysis for the ROV. This report includes deck-layouts and general deployment and recovery procedures for the ROV from the site dedicated vessel as well as detailed drawings of the ROV control van.

5.2 Task 005 – ROV Installation Aboard Site-Dedicated Vessel

SEI will complete an installation report, including documentation of the integration on-board the vessel. SEI anticipates that the integration into the site-dedicated vessel, will occur sometime between April and May of 2017.

5.1 Task 006 – Interim and Final Reports

At 6-month and 18-month points after installation of the ROV on the vessel, SEI will analyze the utility and role of the ROV at WETS.

APPENDIX I: FACILITY ACCEPTANCE TEST

Schedule D: ACCEPTANCE CERTIFICATE

ACCEPTANCE CERTIFICATE

PURCHASER: Sea Engineering Inc.

EQUIPMENT: Super Mohawk 36 ROV

CONTRACT REFERENCE: QTE150914AR5 DATE: 9th March 2016

This Acceptance Certificate is issued in accordance with Section 10.0 – “ACCEPTANCE”, of the Contract. The Equipment has been supplied in accordance with the stated terms and conditions of the Contract. This certifies acceptance that the performance of the Equipment meets the requirements of the Specifications detailed in the FAT Document for the Equipment.

This Acceptance Certificate also serves as confirmation of notification to Sea Engineering Inc. of the Import and Export responsibilities stated in Section 12.0 - “EXPORT CONTROL LAWS” of the Contract.

SELLER:

PURCHASER:

Forum Energy Technologies (UK) Ltd.

Sea Engineering Inc.

Signed:

Signed: 

Name: Lee Allardice

Name: Andrew Rocheleau

Title: Project Manager

Title: Marine Operations Manager

Date:

Date: December 22, 2016

Note: Please see attached FAT discrepancy List

Item	FAT Test Description	Customer FAT Remarks	FET Actions - status	FAT Discrepancy Status	Further Actions
1	Section 1 - Control Console - Ref19 Composite Video Picture quality	Forum to fix & provide proof 'HUM Bars on the monitor showing the rear facing picture	15/Dec/2016 - Forum has since discovered the picture quality issue was caused by faulty camera cable. Forum to provide FOC replacement cable.	Open	Forum to provide FOC camera cable by the 31st January 2017. If vehicle is shipped before cable arrives, FET will send to Sea Engineering
2	Section 1 - Control Console - Ref24 HD Video Recording.	Will get 3rd camera input.	HD video recorder is only capable of single channel recording. Further clarification required.	Closed	
3	Section 2 - Vehicle - Ref 2 Fibre optical signal strength	Forum has ordered new CWDM - will show results.	The FAT requires clarification as to the intent of the test. We have included both optical power and optical loss figures and can confirm that these values are satisfactory for normal system operation. 15/Dec/2016 - Forum fit new CWDM. Signal strength and system losses are as follows; Absolute power measured at ROV mux board = -9.5dBm. System loss measured between Console mux board and ROV mux board = -4.1 dB.	Closed	N/A
4	Section 2 - Vehicle - Ref 21 Gigabit Ethernet	Need to recheck CCTV after changing CWDM.	Checked as per FAT requirement. 16.12.16. Passed.	Closed	N/A
5	Section 2 - Vehicle - Ref 29 & 30 Cable routing	Forum will fix routing and rotate camera connector.	15/Dec/16 - Rerouted cabling and corrected cable connector orientation.	Closed	N/A
6	Section 2 - vehicle - Ref 36 Buoyancy	Forum to provide plan to relocate flotation.	15/Dec/2016 - Forum to supply quote regarding additional survey equipment. Plan to relocate buoyancy will be a part of the quote.	Closed	Forum to supply quote by 31st Dec 2016
7	Section 2 - Vehicle - Ref 52 ROV 100% load current meter	Pegging on the meter on the SCU	15/Dec/2016 - Additional electrical and hydraulic modifications and testing carried out. Power budget to be discussed with client. (See item 16 also)	Discussed with Andrew Rocheleau during call 16th Dec.	N/A
8	Section 2 - Vehicle - Ref 52 ROV load current meter	Off scale 25+ on the meter in the SCU	15/Dec/2016 - Additional electrical and hydraulic modifications and testing carried out. Power budget to be discussed with client. (See item 16 also)	Discussed with Andrew Rocheleau during call 16th Dec.	N/A
9	Section 3 - Tooling - Ref 7 Tooling 4' cutter	System unable to perform cut within satisfactory timescale at time of FAT.	15/Dec/2016 - System performs successful cutting operation. Client provided with video evidence.	Closed	N/A
	Additional Post FAT Comments	Source reference	FET Actions	Status/Date	
10	No fan on the third light control board	E-mail Andrew Rocheleau (31Oct16)	16/Dec/2016 - Will be done prior to vehicle delivery	Completed	N/A
11	Hot Melt over with 120V	E-mail Andrew Rocheleau (31Oct16)	28/Nov/16 - 120VAC version supplied with spares	Completed	N/A
12	Quotation requested for hand controller for second manipulator.	E mail Andrew Rocheleau (31Oct16)	Outstanding.	Ongoing	Forum to supply quote by 31st Dec 2016
6.A. - Buoyancy for vehicle to be relocated/arranged per the SM36 customer layout document, provided by James Foster, 5/4/2016, and attached at the end of the FAT acceptance certificate for reference.					

13	Quotation requested for ROV Van Rack.	E-mail Andrew Rocheleau (31Oct16)	Forum will supply rack FOC.	Completed	N/A
14	Submit spares list for client approval.	E-mail Andrew Rocheleau (31Oct16)	Forum to update spares list.	Ongoing	Forum to supply quote by 31st Dec 2016
15	ROV breaker on transformer tripping with high loads.	E-mail Andrew Rocheleau (31Oct16)	15/dec/2016 - Circuit breaker updated from 20A to 25A. Additional electrical and hydraulic modifications and testing carried out. Power budget to be discussed with client. (See Item16 also.)	Discussed with Andrew Rocheleau during call 16th Dec.	N/A
16	Post FAT System Upgrades.	Upgrades to electrical system include: Cable from transformer to SCU Transformer to MCB wiring. MCB in enclosure increased from 20A to 25A. SCU internal wiring changed to reduce losses and to provide extra deck cable connections. Deck cable re-terminated to provide parallel connections for ROV. Re-defined intermittent duty rating for transformer. Re-defined intermittent duty rating for slip rings.	Upgrades to hydro/mechanical system include: Revised pipework configuration to reduce losses. Improvements to HPU unloading circuit. Selection of different cutting disk to optimise performance. (Can cut through 25T shackle in approx 6 minutes.)	N/A	N/A

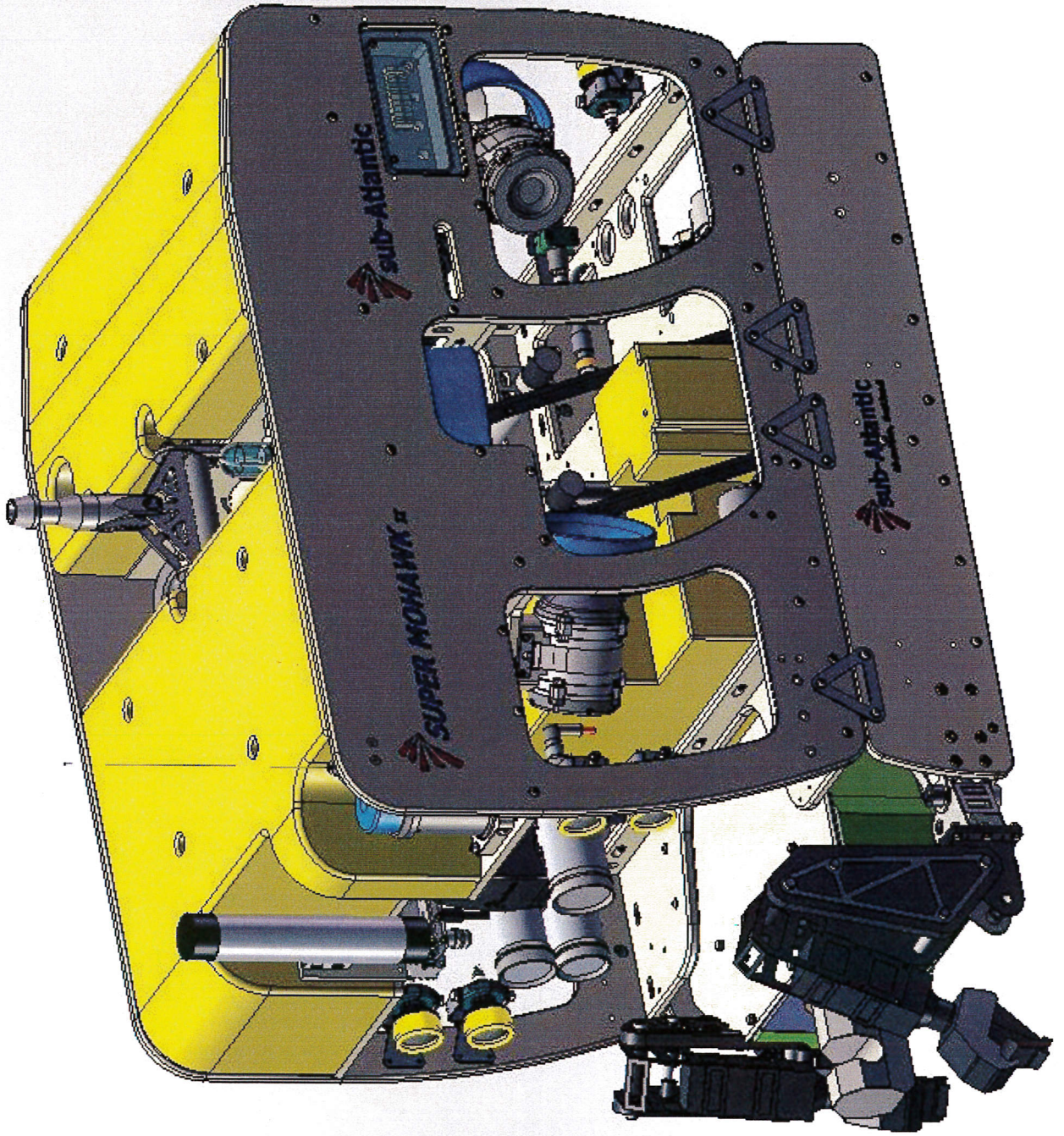

APPENDIX II: SUPER MOHAWK 36 INVOICES (GBP)



Forum Subsea Technologies

Ings Lane
Kirkbymoorside
YORK, North Yorkshire YO62 6EZ

Phone +44 (0)1751 431751 Fax +44 (0)1751 431388

VAT Reg No.: GB808964001

End Use Reg: SC238859

FORUM SUBSEA TECHNOLOGIES IS A BUSINESS LINE OF FORUM ENERGY TECHNOLOGIES (UK) LTD

INVOICE

Invoice PSINV045422
Customer PO 150914
Invoice Date 23-Mar-2016
Customer # C0420
Customer VAT #
Order No.
Page Number Page 1

Payment Terms Due on Contract
Currency GBP
Shipping Terms Not Applicable - Manual In

Prepared By
Confirm To Mailani Laufasa

B Sea Engineering Inc
I 863 N. Nimitz Hwy
L Honolulu, HI 96817
L United States of America
United States
T
O

S Sea Engineering Inc
H 863 N. Nimitz Hwy
I Honolulu, HI 96817
P United States of America
United States
T
O

VAT Reg:

Line No. Item No.
10000

Your Item No.

Description
SUPER MOHAWK 36
Milestone Payment1:
25% Due on Contract

Quantity U/M
1 EACH

Unit Price
116,833.00

Disc.
%

Amount
116,833.00

Sales Order: SO36595

FAO: Andrew Rocheleau

Total GBP

116,833.00



Forum Energy Technologies (UK) Limited

Ings Lane, Kirkbymoorside,
York, North Yorkshire,
YO62 6EZ.

Handwritten signature and date: 23/03/16

Bank Details: GBP A/C (HSBC)
Sort Code: 400125
Account No.: 91322141
IBAN: GB06MIDL40012591322141
SWIFT: MIDLGB22

Incoterms 2010 NA ###

Terms & Conditions

Orders are subject to our standard terms and conditions, copy available on request

No. of Cases	NET Weight (Kg)	GROSS Weight (Kg)



Forum Subsea Technologies
 Ings Lane
 Kirkbymoorside
 YORK, North Yorkshire YO62 6EZ

Phone +44 (0)1751 431751 Fax +44 (0)1751 431388
 VAT Reg No.: GB808964001
 End Use Reg: SC238859
 FORUM SUBSEA TECHNOLOGIES IS A BUSINESS LINE OF FORUM ENERGY TECHNOLOGIES (UK) LTD

INVOICE

Invoice PSINV046209
 Customer PO 150914
 Invoice Date 22-Jul-2016
 Customer # C0420
 Customer VAT #
 Order No.
 Page Number Page 1

Payment Terms 30 Days
Currency GBP
Shipping Terms Not Applicable - Manual In

Prepared By
Confirm To Mailani Laufasa

B | Sea Engineering Inc
 I | 863 N. Nimitz Hwy
 L | Honolulu, HI 96817
 L | United States of America
 United States
 T
 O

S | Sea Engineering Inc
 H | 863 N. Nimitz Hwy
 I | Honolulu, HI 96817
 P | United States of America
 United States
 T
 O

VAT Reg:

Line No.	Item No.	Your Item No.	Description	Quantity	U/M	Unit Price	Disc. %	Amount
	10000		SUPER MOHAWK 36 Milestone Payment 2: 25% Due on Frame Load Test	1	EACH	116,833.00		116,833.00
Total GBP								116,833.00

Sales Order: SO36595

FAO: Andrew Rocheleau



Forum Energy Technologies (UK) Limited

Ings Lane, Kirkbymoorside,
 York, North Yorkshire
 YO62 6EZ.

M. Schubert - 22/07/16.

No. of Cases	NET Weight (Kg)	GROSS Weight (Kg)

Bank Details: GBP A/C (HSBC)
 Sort Code: 400125
 Account No.: 91322141
 IBAN: GB06MIDL40012591322141
 SWIFT: MIDLGB22

Incoterms 2010 NA ###

Terms & Conditions

Orders are subject to our standard terms and conditions, copy available on request



Forum Subsea Technologies

Ings Lane
Kirkbymoorside
YORK, North Yorkshire YO62 6EZ

Phone +44 (0)1751 431751 Fax +44 (0)1751 431388

VAT Reg No.: GB808964001

End Use Reg: SC238859

FORUM SUBSEA TECHNOLOGIES IS A BUSINESS LINE OF FORUM ENERGY TECHNOLOGIES (UK) LTD

INVOICE

Invoice PSINV046562

Customer PO 150914

Invoice Date 22-Sep-2016

Customer # C0420

Customer VAT #

Order No.

Page Number Page 1

Payment Terms 30 Days

Currency GBP

Shipping Terms Not Applicable - Manual In

Prepared By

Confirm To Mailani Laufasa

B | Sea Engineering Inc
I | 863 N. Nimitz Hwy
L | Honolulu, HI 96817
L | United States of America
United States
T
O

S | Sea Engineering Inc
H | 863 N. Nimitz Hwy
I | Honolulu, HI 96817
P | United States of America
United States
T
O

VAT Reg:

Line No.	Item No.	Your Item No.	Description	Quantity	U/M	Unit Price	Disc. %	Amount
	10000		SUPER MOHAWK 36 Milestone Payment 3: 25% Due on Start of Integration Sales Order: SO36595 FAO: Andrew Rocheleau	1	EACH	116,833.00		116,833.00
Total GBP								116,833.00



Forum Energy Technologies (UK) Limited

Ings Lane, Kirkbymoorside,
York, North Yorkshire,
YO62 6EZ.

Handwritten signature 22/9/16

No. of Cases	NET Weight (Kg)	GROSS Weight (Kg)

Bank Details: GBP A/C (HSBC)
Sort Code: 400125
Account No.: 91322141
IBAN: GB06MIDL40012591322141
SWIFT: MIDLGB22

Incoterms 2010 NA ###

Terms & Conditions

Orders are subject to our standard terms and conditions, copy available on request



Forum Subsea Technologies
 Ings Lane
 Kirkbymoorside
 YORK, North Yorkshire YO62 6EZ

Phone +44 (0)1751 431751 Fax +44 (0)1751 431388

VAT Reg No.: GB808964001

End Use Reg: SC238859

FORUM SUBSEA TECHNOLOGIES IS A BUSINESS LINE OF FORUM ENERGY TECHNOLOGIES (UK) LTD

INVOICE

Invoice PSINV047095
 Customer PO 36595
 Invoice Date 23-Dec-2016
 Customer # C0420
 Customer VAT #

Order No.
 Page Number Page 1

Payment Terms 30 Days
Currency GBP
Shipping Terms Not Applicable - Manual In

Prepared By
Confirm To Mailani Laufasa

B Sea Engineering Inc
 I 863 N. Nimitz Hwy
 L Honolulu, HI 96817
 L United States of America
 United States
 T
 O

S Sea Engineering Inc
 H 863 N. Nimitz Hwy
 I Honolulu, HI 96817
 P United States of America
 United States
 T
 O

VAT Reg:

Line No.	Item No.	Your Item No.	Description	Quantity	U/M	Unit Price	Disc. %	Amount
	10000		SUPER MOHAWK 36 Milestone Payment4: 25% - Completion of FAT prior to delivery Sales Order: SO36595 FAO: Andrew Rocheleau	1	EACH	116,833.00		116,833.00
Total GBP								116,833.00



Forum Energy Technologies (UK) Limited
 Ings Lane, Kirkbymoorside,
 York, North Yorkshire,
 YO62 6EZ.

[Signature]
 23/12/2016

No. of Cases	NET Weight (Kg)	GROSS Weight (Kg)

Bank Details: GBP A/C (HSBC)
 Sort Code: 400125
 Account No.: 91322141
 IBAN: GB06MIDL40012591322141
 SWIFT: MIDLGB22

Incoterms 2010 NA ###

Terms & Conditions

Orders are subject to our standard terms and conditions, copy available on request

APPENDIX V: ROV INSTALLATION COMPLETION REPORT

University of Hawai'i Office of Research Services: Asia-Pacific Research Initiative for Sustainable Energy Systems 2012

**Wave Energy Testing
Task 005: ROV Installation Completion Report**

Kāneʻohe Marine Corps Base, Oʻahu , Hawai'i



Prepared for:

University of Hawai'i Office of Research Services:
Asia-Pacific Research Initiative for Sustainable
Energy Systems 2012

Prepared by:

Sea Engineering, Inc.
863 N. Nimitz Hwy
Honolulu, HI 966817
Job No. 13001



Table of Contents

1. INTRODUCTION	3
2. PROJECT LOCATION	4
3. SUPER MOHAWK INSTALLATION & OPERATIONAL ASSESSMENT	5
3.1 SUPER MOHAWK – MODULAR SYSTEM SETUP	6
3.1.1 Generator	6
3.1.2 Control Container	7
3.1.3 Deck Winch	9
3.1.4 Super Mohawk ROV	11
4. ROV INSTALLATION AND MOBILIZATION.....	12
5. SUMMARY	13
6. APPENDIX I: MULTIQUIP DCA45SSIUF DIESEL GENERATOR SPEC SHEET	14
7. APPENDIX II: ROV JUNCTION BOX TERMINATION – VERSION A	19
8. APPENDIX III: FIXED JUNCTION BOX TERMINATION – VERSION A.....	20
FIGURE 1. KĀNE’OHE MARINE CORPS BASE HAWAI’I – WAVE ENERGY TEST SITE	4
FIGURE 2. ROV GENERATORS AND TRANSFORMERS.....	7
FIGURE 4. ROV CONTROL CONSOLE	8
FIGURE 3. POWER DISTRIBUTION PANEL.....	9
FIGURE 5. DECK WINCH WITH SUPER MOHAWK ROV UMBILICAL LOADED ONTO WINCH.....	10
FIGURE 6. DECK WINCH SLIP RING.....	10
FIGURE 6. ROV COMPONENT LAYOUT	12

1. INTRODUCTION

In support of the University of Hawai‘i’s Project “Asia-Pacific Research Initiative for Sustainable Energy Systems 2012 (APRISES12), Task 4.2, “Wave Energy Testing”, Sea Engineering Inc. (SEI) was contracted to assess remotely operated vehicle (ROV) requirements at the U.S. Navy Wave Energy Test Site (WETS), conduct a market study of available ROV solutions, purchase an ROV to support University of Hawai‘i, Department of Energy, and US Navy Research objectives at WETS, and, through use of the ROV, to conduct an analysis of the utility and limitations of that ROV in support of wave energy test objectives.

The ROV will provide important research, maintenance and emergency response capabilities that are expected to greatly enhance the ability of the DOE and Navy at WETS.

Tasks under the Agreement for Services include:

- Task 001: Requirements Assessment
- Task 002: Market Study of Available ROVs
- Task 003: ROV Procedural Analysis
- Task 004: ROV Purchase
- Task 005: ROV Installation Aboard Site-Dedicated Support Vessel
- Task 006a: ROV Operational Assessments Report #1
- Task 006b: ROV Operational Assessments Report #2
- Task 006c: ROV Final Report

This report presents the results of Task 005 – ROV Installation Aboard Site-Dedicated Support Vessel.

2. PROJECT LOCATION

ROV studies and operations are based on work anticipated at the Kāneʻohe Marine Corps Base (MCBH) Wave Energy Test Site (WETS). The Wave Energy Test Site is located on the windward side of the Island of Oʻahu, offshore of the Kāneʻohe Marine Corps Base Hawaiʻi. The test site is located northeast of Heʻeia Kea Small Boat Harbor within the security zone of MCBH. Key features at WETS, including the 30-meter test site, deep water wave energy test sites (comprised of 60 meter and 80 meter berths), Heʻeia Kea Small Boat Harbor, Dedicated Vessel Approved Mooring Area, Pyramid Rock, Battery French and the MCBH Fuel Pier, are shown in Figure 1.

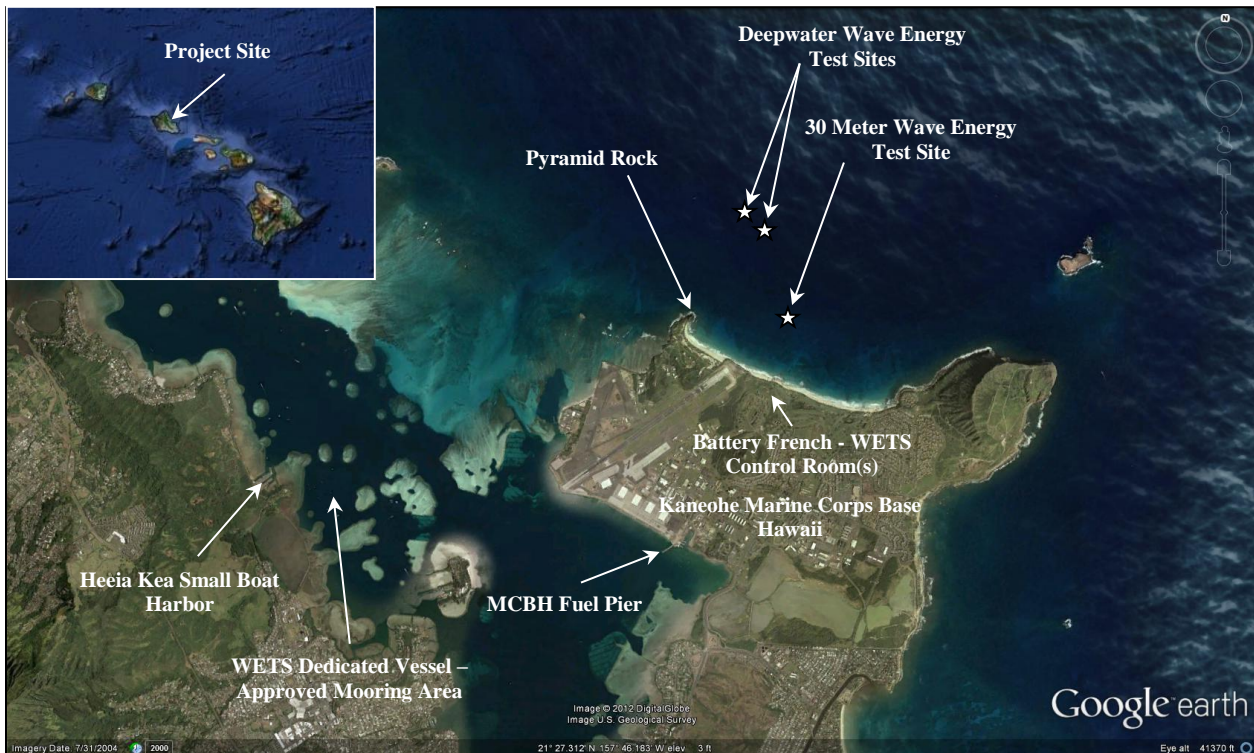

Figure 1. Kāneʻohe Marine Corps Base Hawaiʻi – Wave Energy Test Site

3. SUPER MOHAWK INSTALLATION & OPERATIONAL ASSESSMENT

SEI conducted installation operations for the ROV in early November 2017. In addition to SEI personnel, a vehicle integration technician was on site from Forum Technologies and a veteran ROV operator, hired as a consultant. The installation was completed in two phases, (1) dry testing of the ROV and its components at SEI's Nimitz offices, and (2) wet testing onboard the Huki Pau alongside Pier 26 in Honolulu Harbor.

The dry tests and mobilization tasks included the following:

- Winch hydraulics testing and repair
- Slip ring removal and reinstallation
- Fixed junction box termination
- Tether installation on winch drum
- Rotating junction box termination
- Generator supply voltage test
- Transformer supply voltage test
- SCU supply voltage test
- Voltage tests in the ROV pods
- Fiber loss through the system
- Console and display setup
- Thruster testing
- Camera setup
- Hydraulic manipulator testing
- SubCan control software setup
- Cable cutter test

The wet tests included the following:

- Buoyancy and trim testing
- ROV auto function calibration (auto heading, auto attitude, auto depth, gyro stability)
- Cable cutter test
- ROV controller testing
- Hydraulic function testing (twin manipulator and single manipulator with cutoff wheel)
- USBL positioning system setup

In addition, SEI personnel were trained in fiber termination of 3M ST hot melt connectors, which are utilized during re-termination of the ROV umbilical.

3.1 Super Mohawk – Modular System Setup

SEI has compiled a modular ROV support system for Forum Sub-Atlantic Super Mohawk ROV operations. This will allow the ROV to be operated from multiple vessels including SEI's vessels *Kūpa 'a*, the WETS site dedicated vessel, and SEI's *Huki Pau*. In addition, the modular system will allow the Super Mohawk to be mobilized and deployed from other support vessels such as a Healy Tibbitts crane barge if needed. The modular system consists of four pieces of equipment:

- Generator
- Control Container
- Deck Winch
- ROV

3.1.1 Generator

The power for ROV and its associated components is provided by a Multiquip DCA45SSIU4F 36 kW diesel generator. This generator is trailer mounted and can easily be removed to save space on the vessel. It provides the required 440 volt three phase supply required for ROV operations. The wiring diagram for the generator and the ROV transformer, general propose transformer and deck winch is shown Figure 2. The figure shows the circuit breakers and connectors used to connect the ROV components.

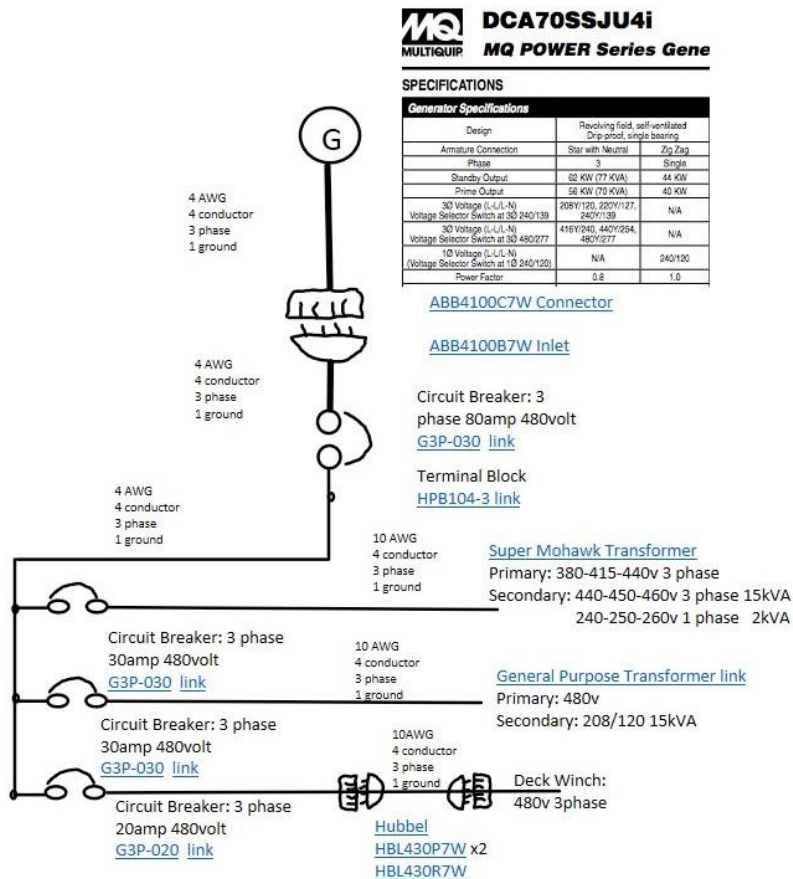

Figure 2. ROV Generators and Transformers

3.1.2 Control Container

The control container is a 20-ft insulated aluminum cargo container, organized such that 70% of the space is dedicated for operations and 30% as a maintenance shop, respectively. Figure 3 highlights the operational end of the control container. Operational equipment includes:

- ROV Rack with Control Boards and ROV Control Hardware
- 32" High Definition Camera Monitor for Main Front Facing HD Camera
- 19" Standard Definition Camera Monitor for Front Facing SD Camera
- 19" Standard Definition Camera Monitor for Rear Camera
- Control Monitor Touch Screen
- 19" Monitor and Laptop for Hypack Navigation Display and Integration with Applied Acoustics Ultra Short Baseline (USBL) EasyTrack Lite positioning system
- Two Videosoft Computers and Hard drives for recording video feeds from ROV
- Communications to Boat Captain, and Deck for Tether and Vessel Management



Figure 3. ROV Control Console

The ROV control container houses the follow control components powered by the generator:

- ROV power distribution panel
- ROV transformer
- ROV control console
- General purpose transformer
- General purpose breaker panel

The ROV power distribution panel consist of a “mains” breaker (three phase) to separate all the system components from the generator shown in the lower part of Figure 4. In line from the mains breaker are the three phase breakers for the ROV transformer, general purpose transformer, and the deck winch shown in the upper part of Figure 4. The ROV transformer outputs 440v three phase (15kVA) and 240v single-phase (2kVA) to supply the ROV control console. The general-purpose transformer outputs 208/120 V (15kVA) to a three-phase circuit breaker panel power for the use of the lights, computers, and other ROV support devices.



Figure 4. Power Distribution Panel

3.1.3 Deck Winch

The deck winch, shown in Figure 6, consists of a hydraulic power unit (HPU), drum and slip ring. A three-phase motor and hydraulic pump provides the pressure required to turn the drum and operate the A-frame.

The primary purpose of the deck winch is to provide a means of efficiently handling the 600m of tether. The slip ring attaches the ROV deck cable to the rotating tether on drum of the deck winch. Figure 6 shows the two junction boxes for the slip ring wiring. The junction box on the left is the fixed box where the ROV deck cable is terminated. The junction box on the right is the rotating box where the tether is terminated. The slip ring is protected by a cage. The slip ring allows for the electrical and fiber connections of the deck cable to be transferred to the rotating tether on the drum.



Figure 5. Deck Winch with Super Mohawk ROV Umbilical Loaded onto Winch

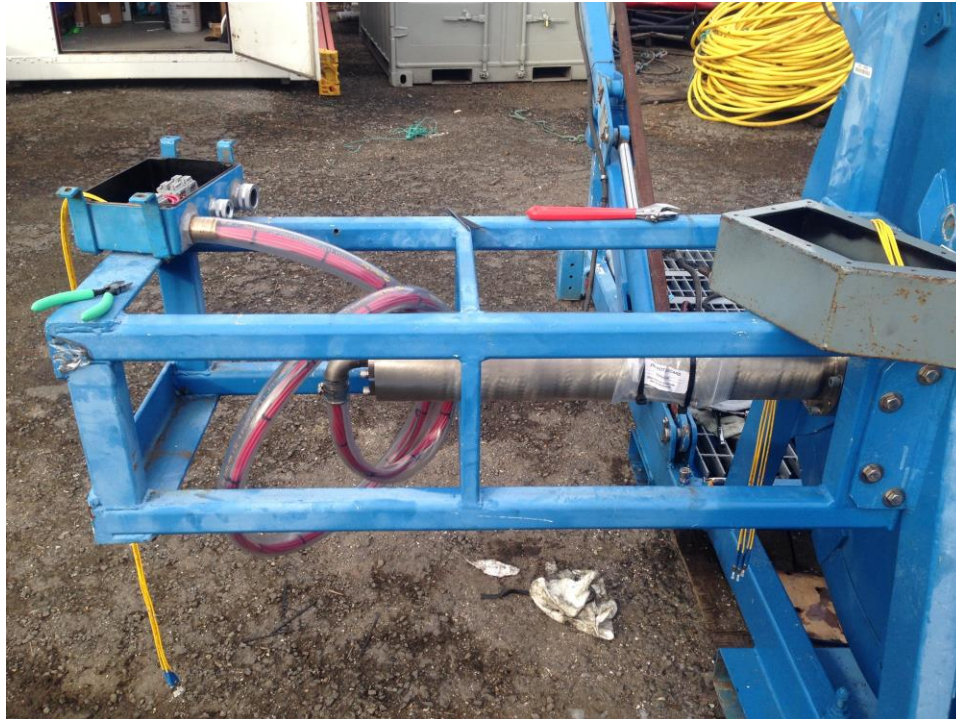

Figure 6. Deck Winch Slip Ring

3.1.4 Super Mohawk ROV

The Super Mohawk ROV will be free-swimming, meaning the vehicle will not be tethered to a recovery winch. The vehicle will be deployed, either from the stern of the vessel, using an A-frame or from the side of the vessel using a deck mounted crane. The ROV is lifted with use of a latching lock that is connected to the winch of a crane or A-frame.

4. ROV INSTALLATION AND MOBILIZATION

The four components of the ROV system can be operated from any vessel that has the required space and lifting requirements. The control container may require a mobile crane to lift the control container on to the vessel (see report cover photo). The weight and dimension of each of the components is shown in Table 1.

Table 1. ROV Component Weight and Dimension

	Weight	Dimension
Control Container	8500lbs	8 ft x 20 ft
Deck Winch with tether	5500 lbs	5ft x 8ft
ROV	1322lbs	36in x 56 in
Generator	2976lbs	37.40 x 83.86 in

Once on-board the vessel of opportunity, ROV components will be connected. The component layout and connectors are shown in Figure 7. The connection between the generator and the control container is a simple industrial plug as is the plug for the winch. The rotating JB will typically remain terminated inside the drum of the winch for storage, thus the slip ring is terminated to the tether. The deck cable will have to be terminated into the fixed junction box connecting the deck cable to the slip ring. The tether will be terminated in to the ROV junction box. The procedure for the ROV junction box termination is attached in Appendix II. The procedure for the Fixed junction box termination is attached in Appendix III. The fixed junction box and the rotating junction box of the slip ring are well used and worn. These boxes will be replaced with new boxes that have new seals.

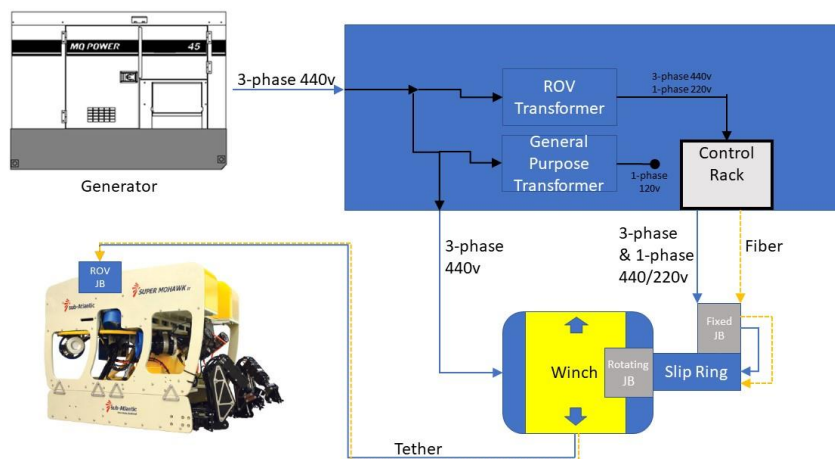

Figure 7. ROV Component Layout

5. SUMMARY

SEI successfully integrated the Super Mohawk ROV into a modular system for deployment from any vessel with the required space and lifting capabilities. Onshore tests and setup were completed to confirm all systems were operational. Following the onshore tests, wet tests were completed pier side from SEI's modified landing craft, the Huki Pau to conclude the integration/installation process. These tests proved that all the vehicle systems were properly functioning.

The Super Mohawk ROV is operational, and can be currently utilized from SEI's vessel, *Huki Pau* or another vessel of opportunity should the need at WETS arise. Once shipbuilding operations on-board *Kūpa 'a* are complete, the Super Mohawk ROV will be loaded and tested on-board the WETS dedicated vessel as well.

6. APPENDIX I: MULTIQUIP DCA45SSIUF DIESEL GENERATOR SPEC SHEET

MQ **DCA45SSIU4F**
MULTISUP. **MQ POWER Series Generator**

WhisperWatt™

Prime Rating — 36 kW (45 kVA)

Standby Rating — 40 kW (50 kVA)

Three-Phase, 60 Hertz, 0.8 PF

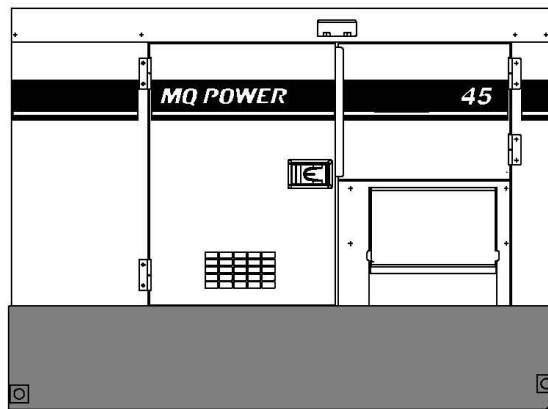

STANDARD FEATURES

- Heavy duty, 4-cycle, direct injection, turbocharged, charge air cooled diesel engine provides maximum reliability.
- Brushless alternator reduces service and maintenance requirements and meets temperature rise standards for Class H insulation systems.
 - Open delta excitation design provides virtually unlimited excitation for maximum motor starting capability.
 - Automatic voltage regulator (AVR) provides precise regulation.
- Electronic Governor Control — isochronous control, maintains frequency to within $\pm 0.25\%$ from no load to full load.
- Full load acceptance of standby nameplate rating in one step (NFPA 110, para 5-13.2.6).
- Sound attenuated, weather resistant, steel housing provides operation at 66 dB(A) at 23 feet. Fully lockable enclosure allows safe unattended operation.
- Internal fuel tank with direct reading of fuel gauge.
- E-coat and powder coat paint provides durability and weather protection.
- Fuel/water separator removes condensation from fuel for extended engine life. Panel mounted alarm light included.
- Complete engine analog instrumentation includes DC ammeter, oil pressure gauge, water temp. gauge, fuel level gauge, tachometer/hour meter, preheat indicator, and emergency shutdown monitors.
- ECU750 — automatic CANBUS engine control with LED status indicator lights.
- Automatic start/stop control — automatically starts the generator set during a commercial power failure when used in conjunction with a transfer switch.
- Complete generator analog instrumentation includes voltage regulator control, ammeter phase selector switch, voltmeter phase selector switch, AC voltmeter, AC ammeter, frequency meter, panel light, and circuit breaker.
- Automatic safety shutdown system monitors the water temperature, engine oil pressure, overspeed and overcrank. Warning lights indicate abnormal conditions.
- Complete power panel. Fully covered; three-phase terminals and single phase receptacles allow fast and convenient hookup for most applications including temporary power boxes, tools and lighting equipment. The GFCI receptacles are NEMA 5-20, and the auxiliary outputs use CS6369 twist-lock receptacles.
- Voltage selector switch offers the operator a wide range of voltages that are manually selectable. Fine tuning of the output voltage can be accomplished by adjusting the voltage regulator control knob to obtain the desired voltage.
- EPA emissions certified — Tier 4 final emissions compliant.
- Spill containment — Bunded design protects environment by capturing up to 119% of engine fluids.

DCA45SSIU4F — MQ POWER SERIES GENERATOR — REV. #2 (10/14/13)



DCA45SSIU4F

MQ POWER Series Generator

SPECIFICATIONS

Generator Specifications	
Design	Revolving field, self-ventilated Drip-proof, single bearing
Armature Connection	Star with Neutral Zig Zag
Phase	3 Single
Standby Output	40 KW (50 KVA) 28.8 KW
Prime Output	36 KW (45 KVA) 26 KW
3Ø Voltage (L-L-L-N) Voltage Selector Switch at 3Ø 240/139	208Y/120, 220Y/127, 240Y/139 N/A
3Ø Voltage (L-L-L-N) Voltage Selector Switch at 3Ø 480/277	416Y/240, 440Y/254, 480Y/277 N/A
1Ø Voltage (L-L-L-N) (Voltage Selector Switch at 1Ø 240/120)	N/A 240/120
Power Factor	0.8 1.0
Voltage Regulation (No load to full load)	±0.5%
Generator RPM	1800
Frequency	60 Hz
No. of Poles	4
Excitation	Brushless with AVR
Frequency Regulation: No Load to Full Load	Isochronous under varying loads from no load to 100% rated load
Frequency Regulation: Steady State	±0.25% of mean value for constant loads from no load to full load.
Insulation	Class H
Sound Level dB(A) Full load at 23 feet	66

Engine Specifications	
Make / Model	Isuzu / 4LE2X
Emissions	EPA Tier 4 Final Certified
Starting System	Electric
Design	4-cycle, water cooled, direct injection, turbocharged, charge air cooled and EGR
Displacement	133.0 in ³ (2179 cc)
No. cylinders	4
Bore x Stroke (mm)	85 x 96
Gross Engine Power Output	65.7 hp (49 kW)
BMEP	217 psi (1499 kPa)
Piston Speed	1133.9 ft./min. (5.76 m/s)
Compression Ratio	17.6:1
Engine Speed	1800 rpm
Overspeed Limit	2070 rpm
Oil Capacity	3.2 gallons (12.2 liters)
Battery	12V 72Ah x 1

Fuel System		
Recommended Fuel	ASTM-D975-No.1 & No.2-D	
Maximum Fuel Flow (per hour)	3.4 gallons (13 liters)	
Maximum Inlet Restriction (Hg)	11 in. (280 mm)	
Fuel Tank Capacity	79.2 gallons (300 liters)	
Fuel Consumption	gph	lph
At full load	2.93	11.1
At 3/4 load	2.20	8.31
At 1/2 load	1.60	6.04
At 1/4 load	1.04	3.92

Cooling System	
Fan Load	2.01 hp (1.5 kW)
Coolant Capacity (with radiator)	4.44 gallons (16.8 liters)
Coolant Flow Rate (per minute)	16.9 gallons (64.2 liters)
Heat Rejection to Coolant (per minute)	1934 Btu (2.04 MJ)
Maximum Coolant Friction Head	14.5 psi (100 kPa)
Maximum Coolant Static Head	3.35 feet (1.04 meters)
Ambient Temperature Rating	104°F (40°C)

Air	
Combustion Air	174 cfm (4.94 m ³ /min)
Maximum Air Cleaner Restriction	25 in. H ₂ O (6.23 kPa)
Alternator Cooling Air	526 cfm (14.9 m ³ /min)
Radiator Cooling Air	1900 cfm (53.8 m ³ /min)
Minimum Air Opening to Room	3.5 ft ² (0.33 m ²)
Minimum Discharge Opening	2.27 ft ² (0.21 m ²)

Exhaust System	
Gas Flow (full load)	237 cfm (6.7 m ³ /min)
Gas Temperature	1078°F (581°C)
Maximum Back Pressure	38.1 in. H ₂ O (9.5 kPa)

Amperage	
Rated Voltage	Maximum Amps
1Ø 120 Volt	100 Amps (4 wire), 108A x 2 (Zigzag)
1Ø 240 Volt	50 Amps (4 wire), 108A (Zigzag)
3Ø 240 Volt	108 Amps
3Ø 480 Volt	54 Amps
Main Line Circuit Breaker Rating	125 Amps
Over Current Relay Trip Set Point 480V Mode Only	54 Amps

WARRANTY*

Isuzu Engine

12 months from date of purchase with unlimited hours or 24 months from date of purchase with 2000 hours (whichever comes first).

Generator

24 months from date of purchase or 2000 hours (whichever occurs first).

Trailer

12 months excluding normal wear items.

*Refer to the express written, one-year limited warranty sheet for additional information.

NOTICE

Generator is not intended for use in enclosed areas or where free flow of air is restricted.

Backfeed to a utility system can cause electrocution, shock and/ or property damage. **DO NOT** connect to any building's electrical system except through an approved device.

Specifications are subject to change without notice.

DCA45SSIU4F— MQ POWER SERIES GENERATOR — REV. #2 (10/14/13)

MQ **DCA45SSIU4F**
 MULTIQUIP **MQ POWER Series Generator**

MQ POWER DECIBEL LEVELS

Our soundproof housing allows substantially lower operating noise levels than competitive designs. WhisperWatts are at home on construction sites, in residential neighborhoods, and at hospitals — just about anywhere.

- 90 — Subway / truck traffic
- 80 — Average city traffic
- 70 — Inside car at 60 mph
 — WhisperWatt at 23 feet
- 60 — Air conditioner at 20 feet
- 50 — Normal conversation



OPTIONAL GENERATOR FEATURES

- **Battery Charger** — provides fully automatic and self-adjusting charging to the generator's battery system.
- **Jacket Water Heater** — for easy starting in cold weather climates.
- **Special Batteries** — long life batteries provide extra engine cranking power.
- **Low Coolant Level Shutdown** — provides protection from critically low coolant levels. Includes control panel warning light.
- **Spring Isolators** — provides extra vibration protection for standby applications.
- **Trailer Mounted Package** — meets National Highway Traffic Safety Administration (NHTSA) regulations. Trailer is equipped with electronic or surge brakes with double or triple axle configuration.

GENERATOR OUTPUT PANEL

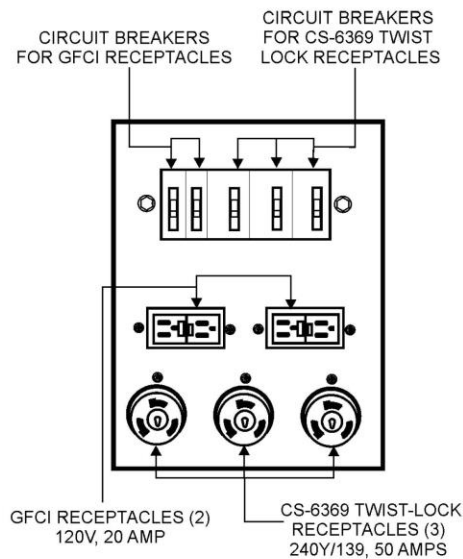

OPTIONAL CONTROL FEATURES

- **Emergency Stop Switch** — when manually activated shuts down generator in the event of an emergency.
- **Audible alarm** — alerts operator of abnormal conditions

OPTIONAL OUTPUT CONNECTIONS

- **Cam-Lok Connectors** — provides quick disconnect alternative to bolt-on connectors.
- **Pin and Sleeve Connectors** — provides industry standard connectors for all voltage requirements.
- **Output Cable** — available in any custom length and size configuration.

DCA45SSIU4F — MQ POWER SERIES GENERATOR — REV. #2 (10/14/13)

MQ **DCA45SSIU4F**
MULTIQUIP **MQ POWER Series Generator**

DIMENSIONS

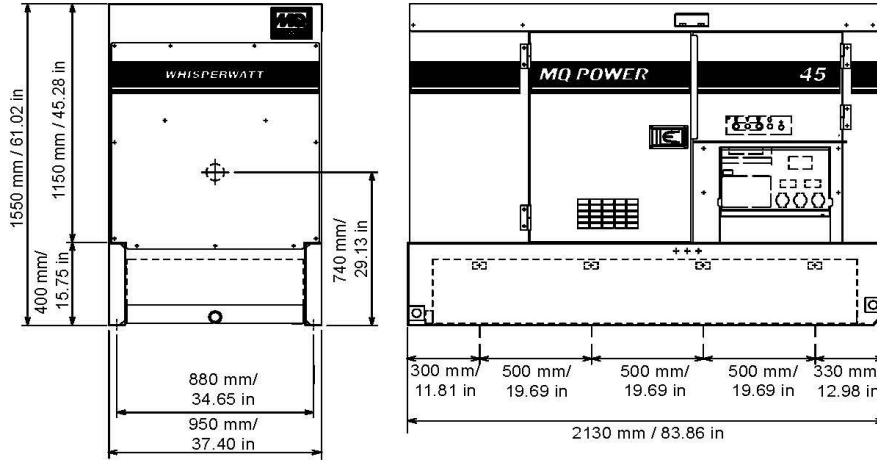

Weight	
Dry Weight	2,337 lbs. (1,060 kg)
Wet Weight	2,976 lbs. (1,350 kg)
Max. Lifting Point Capacity	5,150 lbs. (2,335 kg)

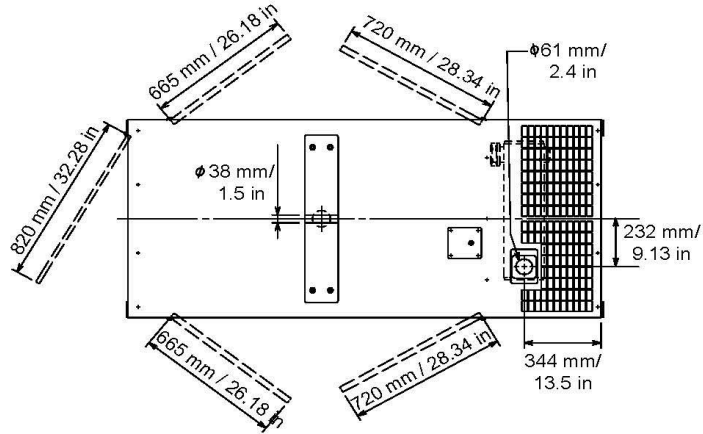

Generator can be placed on
 MQ Power Model TRLR45
 Trailer.

Manufactured by Denyo Co.

Your Multiquip dealer is:

© COPYRIGHT 2013 MULTIQUIP INC.
 DCA45SSIU4F Rev. #2 (10/14/13)



MULTIQUIP
 POST OFFICE BOX 6254
 CARSON, CA 90749
 310-537-3700 • 800-883-2551
 FAX: 310-604-3831
 E-MAIL: sales@multiquip.com
 WEBSITE: www.multiquip.com

7. APPENDIX II: ROV JUNCTION BOX TERMINATION – VERSION A



Procedure Name: ROV Junction Box Termination

Description: Termination of the junction box on the ROV. The tether enters the junction box with the 3-phase 440-volt power for the thrusters, 1-phase 240-volt power for electronics, and optical fibers for communication. This document details the connections made in ROV Junction Box. The termination of the ROV junction box is the last connection to be made when mobilizing the ROV.

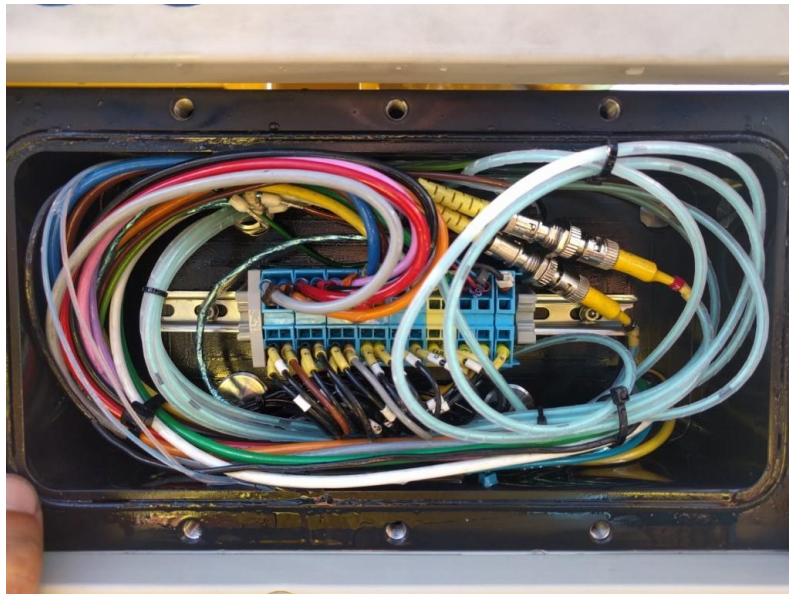

Revision List:

1/2/2018	A -	Original Document

Attachments:

1	Longline wiring diagram
2	



Secure Power

At this point in the mobilization procedure the generator has been terminated to the container and the deck cable is connected to the SCU and the fixed junction box on the deck winch. All circuit breakers are off and no power is supplied to the system.

Physically attach the tether to the ROV

Feed the tether and the “Chinese finger clamp” down through the lifting bracket of the ROV and then through the hole in the frame plate. Then attach the shackle to the two loops in the “Chinese finger clamp” and secure the shackle pin with a zip tie or seizing wire. The loops of the clamp must be feed through frame hole one at a time. Secure the IMANCO bullet to the lifting bracket of the ROV with the two pins.





Now feed the end of the tether into the ROV junction box through the Hawke Fitting (501/453/BX 25mm EExd11CBAS Ex85B1259U). Make sure to not kink the wires in the fitting as shown. Once all the wires and fibers are feed through the junction box and Hawke fitting the fitting can be tightened up. The Hawke fitting is a double seal on the outer casing of the ROV tether. Oil from the ROV junction box will work its way into the tether over time due to the pressure of the oil filled compensator.

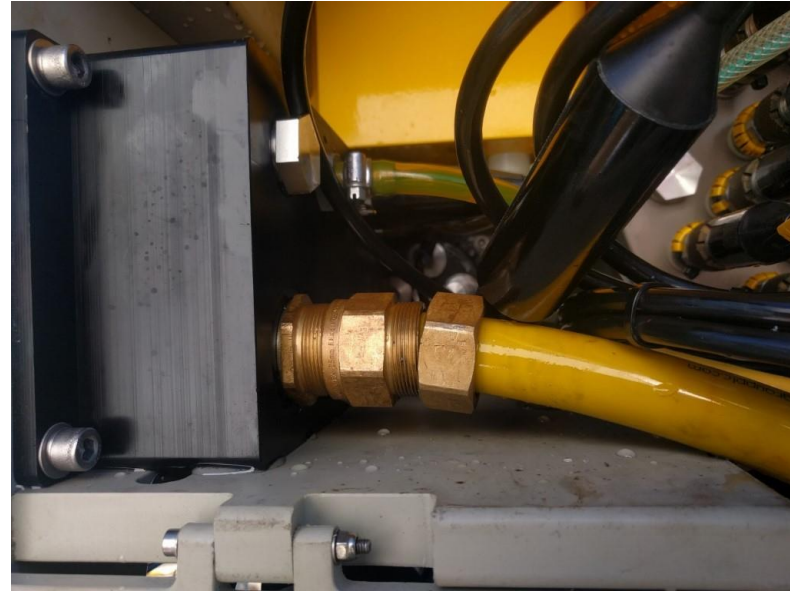
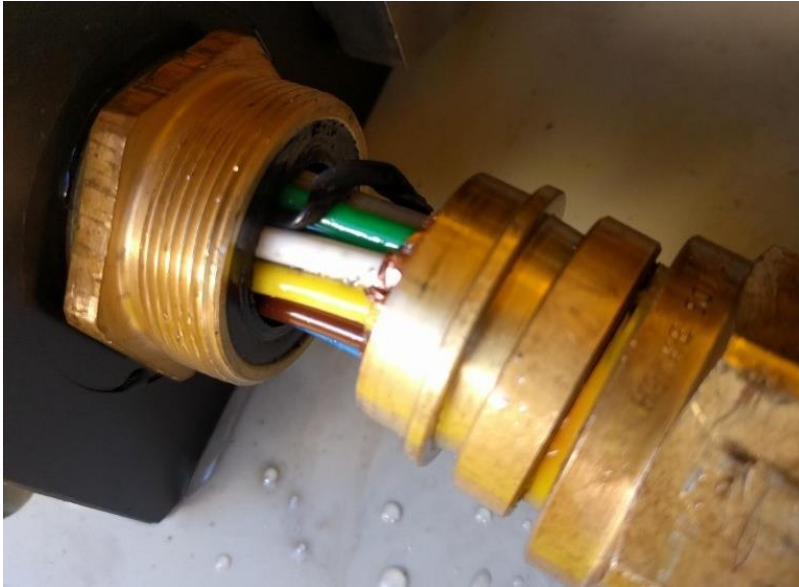



Electrical and Fiber Connections

There are three sets of connections in the ROV junction box, the 3-phase 440 volt electrical connections for the thrusters, the 1-phase 240 volt for the electronics, CP probe connections, and the optical fiber connections for communications between the ROV and the SCU. Connections are made using the push clamp terminal blocks mounted on a DIN rail.

The first phase is the grey and orange wires, the second is red and black, and the third is pink and violet, lastly the neutral connection is the brown and blue wires. These wires are physically connected at the din rail terminal blocks. These are connected to the numbered black wires on the ROV side of the terminal blocks. These make up the 3-phase 440 volt power supply for the thrusters. On the ROV side of the terminal blocks each phase is split two leads, one the ROV Pod and one a relay box.

The 1-phase power is supplied through the yellow (hot or live), white (neutral), and green (ground) wire.

The CP probe connections are made using the smaller gauge red, blue, and black wires.

There are four optical fibers in the tether, labeled by color on the tether side. These are used for the ROV communications between the ROV and the SCU and the Survey connection for a scanning sonar etc. These connectors are the ST type optical fiber connector.

Once all the electrical and fiber connections are made in the junction box the box can be sealed up. Inspect the O-ring and replace if necessary. The O-ring may need a little grease in the O-ring trace to help retain it in trace. Replace the junction box lid and tighten the fasteners.

Refilling the Diala

Now the junction box is sealed at the Hawke fitting and the O-ring lid. Oil will fill the hose that houses the wires to leading to relay box and the ROV pod. Oil will penetrate the tether somewhat as well. The ROV junction box must be filled with transformer oil (diala). The fill port for the compensator is just forward of the ROV junction box. The connection is a (Quick Disconnect) QD type connection. Attach the garden sprayer diala oil pump to the compensator fill port and open the valve. Be sure to not add air into the system by bleeding the air out of the garden sprayer fill tube.

Detail	Tether	ROV
3-phase 440-volt	Gray #1	Thruster Phase 1 Relay box Phase 1
	Orange #1	
	Red #2	Thruster Phase 2 Relay box Phase 2
	Black #2	
	Pink #3	Thruster Phase 3 Relay box Phase 3
	Violet #3	
	Brown #4	Thruster Neutral 4
1-phase 240-volt	Blue #4	
	Yellow #5	ROV Live 5
Ground	White #6	ROV Neutral 6
	Green "Earth"	Ground wire
CP probe	Red	7
	Blue	8
	Black	9
Optical Fibers	Orange	1 ROV
	Clear	2 Survey
	Blue	3 Spare
	Yellow	4 Spare

8. APPENDIX III: FIXED JUNCTION BOX TERMINATION – VERSION A



Procedure Name: Fixed Junction Box Termination

Description: Termination of the fixed junction box on the slip ring of the deck winch. The deck cable that connects the surface control unit (SCU) to the slip ring is terminated in the fixed junction box. The deck cable enters the fixed junction box the 3-phase 440-volt power for the thrusters, 1-phase 240-volt power for electronics, and optical fibers for communication. This document details the connections made in fixed junction box. The termination of the fixed junction box should be done after the deck cable is connect to the SCU via the large plug and the generator has been connected to the container.

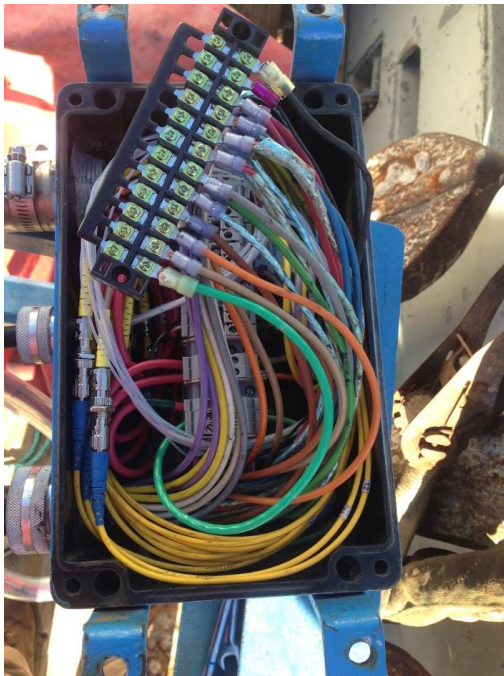

Revision List:

1/3/2018	A -	Original Document

Attachments:

1	Slip ring drawing
2	Longline wiring diagram



Secure Power

At this point in the mobilization procedure the generator has been terminated to the container and the deck cable is connected to the SCU. All circuit breakers are OFF and no power is supplied to the system. The circuit breakers for the ROV transformer and the deck winch are open (OFF).

Slip ring

The slip ring connects the fixed (non-rotating) deck cable to the tether (rotating). The electrical connections are maintained using rings and the fiber connections are made using prisms or mirrors. There are two junction boxes attached to the slip ring, one on either side of the slip ring, the fixed and rotating junction box. The rotating junction is inside the deck winch drum, and generally remains connected to the tether.

Fixed Junction Box

The deck cable is disconnected from the slip ring at the fixed junction box. The deck cable has many multiple wires that are unused for the current ROV setup. These wires are linked together in separate terminal block with spade connectors in the fixed junction box and grounded. This is shown in the picture on the first page of the procedure. The used wires are connected in the screw pin type terminal block mounted on the DIN rail. The table to the right will show the connections to be made. Be sure to check each connection by pulling the wire to confirm that it is secure. Inspect the junction box lid and seal and close the box. Mount the box on the slip ring cage.

Fixed Junction Box

Detail	Use	Deck Cable	Slip Ring
3-phase 440 volt	P1	Violet 1	Red 2
		Violet 2	
		Brown	
	P2	Yellow 3	Red 3
		Yellow 4	
		Red	
	P3	White 5	Red 4
		White 6	
		Blue	
	N	Gray	Red 5
Gray			
1-phase 240 volt	ROV L	Clear 8	Red 6
	ROV N	Orange 9	Red 7
Ground	Earth	Green	Green 1
CP probe	TP	Clear 10	Red 10
		Yellow 11	Black 11
	Shielding	Shielding/black 12	Shielding 9
Optical Fibers	ROV	Clear 1	Yellow 12
	Survey	Clear 2	Yellow 13
	Spare	Clear 3	Yellow 14
	Spare	Clear 4	Yellow 15



REVISIONS				
ZONE	LTR	DESCRIPTION	DATE	APPROVED
-	A	PRODUCTION ISSUE	2016-11	

AS BUILT

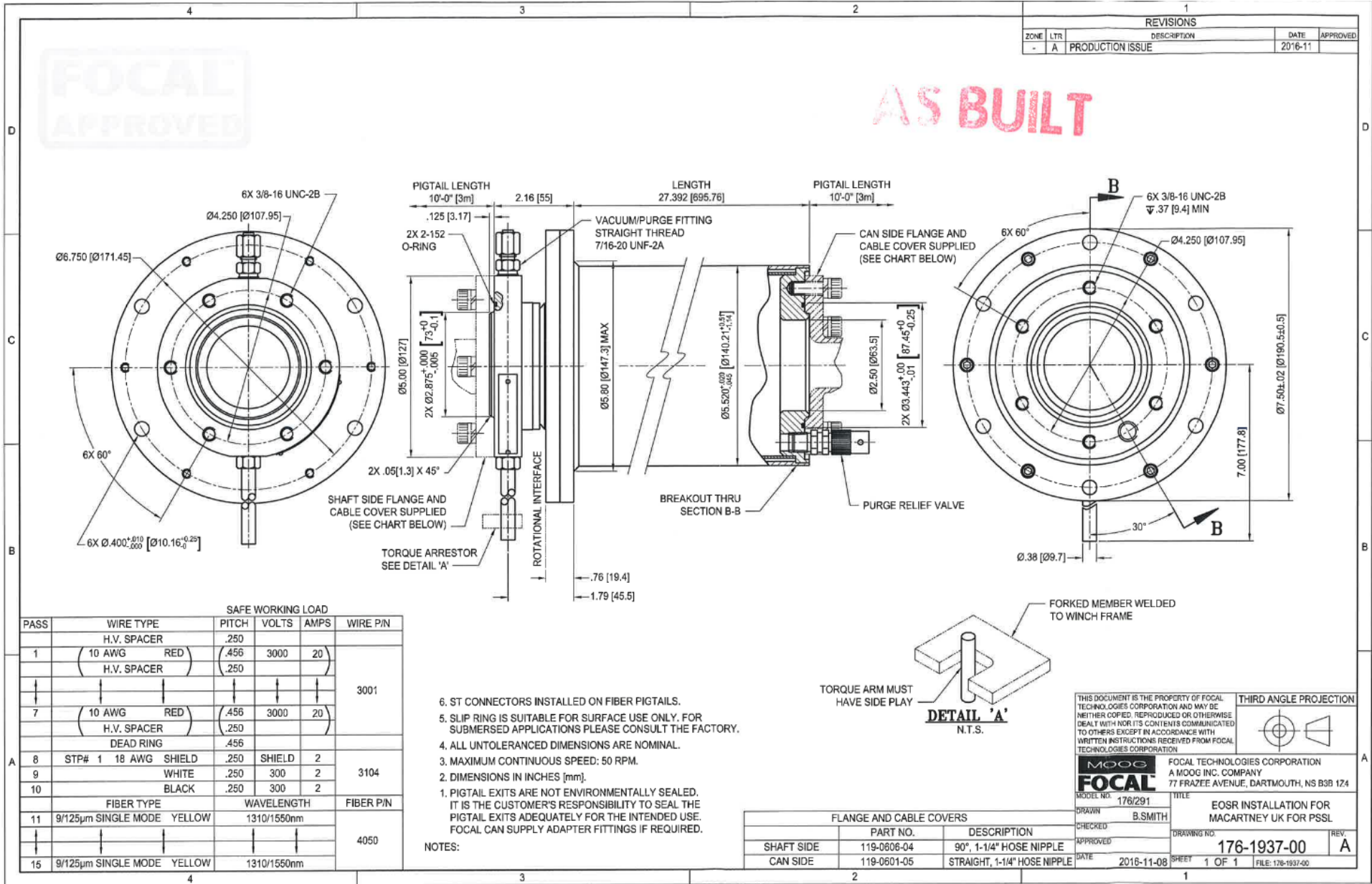

SAFE WORKING LOAD					
PASS	WIRE TYPE	PITCH	VOLTS	AMPS	WIRE P/N
1	H.V. SPACER	.250			3001
	(10 AWG RED)	(.456)	3000	20	
	H.V. SPACER	.250			
7	(10 AWG RED)	(.456)	3000	20	3104
	H.V. SPACER	.250			
	DEAD RING	.456			
8	STP# 1 18 AWG SHIELD	.250	SHIELD	2	4050
9	WHITE	.250	300	2	
10	BLACK	.250	300	2	
	FIBER TYPE	WAVELENGTH	FIBER P/N		
11	9/125µm SINGLE MODE YELLOW	1310/1550nm			
15	9/125µm SINGLE MODE YELLOW	1310/1550nm			

- NOTES:
1. PIGTAIL EXITS ARE NOT ENVIRONMENTALLY SEALED. IT IS THE CUSTOMER'S RESPONSIBILITY TO SEAL THE PIGTAIL EXITS ADEQUATELY FOR THE INTENDED USE. FOCAL CAN SUPPLY ADAPTER FITTINGS IF REQUIRED.
 2. DIMENSIONS IN INCHES [mm].
 3. MAXIMUM CONTINUOUS SPEED: 50 RPM.
 4. ALL UNTOLERANCED DIMENSIONS ARE NOMINAL.
 5. SLIP RING IS SUITABLE FOR SURFACE USE ONLY. FOR SUBMERSED APPLICATIONS PLEASE CONSULT THE FACTORY.
 6. ST CONNECTORS INSTALLED ON FIBER PIGTAILS.

DETAIL 'A'
N.T.S.

TORQUE ARM MUST HAVE SIDE PLAY

FORKED MEMBER WELDED TO WINCH FRAME

FLANGE AND CABLE COVERS	
PART NO.	DESCRIPTION
119-0606-04	90°, 1-1/4" HOSE NIPPLE
119-0601-05	STRAIGHT, 1-1/4" HOSE NIPPLE

THIS DOCUMENT IS THE PROPERTY OF FOCAL TECHNOLOGIES CORPORATION AND MAY BE NEITHER COPIED, REPRODUCED OR OTHERWISE DEALT WITH NOR ITS CONTENTS COMMUNICATED TO OTHERS EXCEPT IN ACCORDANCE WITH WRITTEN INSTRUCTIONS RECEIVED FROM FOCAL TECHNOLOGIES CORPORATION.

THIRD ANGLE PROJECTION

FOCAL TECHNOLOGIES CORPORATION
A MOOG INC. COMPANY
77 FRAZEE AVENUE, DARTMOUTH, NS B3B 1Z4

MODEL NO. 176/291
TITLE: EOSR INSTALLATION FOR MACARTNEY UK FOR PSSL
DRAWN: B.SMITH
CHECKED: []
APPROVED: []
DATE: 2016-11-08

DRAWING NO. 176-1937-00
REV. A
SHEET 1 OF 1
FILE: 176-1937-00

APPENDIX VI: INTERIM OPERATIONAL ASSESSMENT #1

University of Hawai'i Office of Research Services: Asia-Pacific Research Initiative for Sustainable Energy Systems 2012

Wave Energy Testing Task 006a: ROV Operational Assessments Report #1

Kāneʻohe Marine Corps Base, Oʻahu , Hawai'i



Prepared for:

University of Hawai'i Office of Research Services:
Asia-Pacific Research Initiative for Sustainable
Energy Systems 2012

Prepared by:

Sea Engineering, Inc.
863 N. Nimitz Hwy
Honolulu, HI 966817
Job No. 13001



Table of Contents

1. INTRODUCTION	4
2. PROJECT LOCATION	5
3. SUPER MOHAWK OPERATIONAL ASSESSMENT.....	6
3.1 DOCUMENTATION PROCEDURES.....	6
3.2 DECK WINCH MODIFICATIONS	9
4. SUMMARY	10
5. APPENDIX I: MODIFICATION REPORT	11
6. APPENDIX II: PRE-DIVE CHECKLIST.....	19
7. APPENDIX III: POST-DIVE CHECKLIST.....	21
8. APPENDIX IV: ELECTRICAL CONNECTIONS CHECKLIST.....	22
FIGURE 2-1. KĀNE‘OHE MARINE CORPS BASE HAWAI‘I – WAVE ENERGY TEST SITE	5
FIGURE 3-1 DIVE LOG	7
FIGURE 3-2 MAINTENANCE LOG.....	8
FIGURE 3-3 DECK WINCH.....	9

1. INTRODUCTION

In support of the University of Hawai‘i’s Project “Asia-Pacific Research Initiative for Sustainable Energy Systems 2012 (APRISSES12), Task 4.2, “Wave Energy Testing”, Sea Engineering Inc. (SEI) was contracted to assess remotely operated vehicle (ROV) requirements at the U.S. Navy Wave Energy Test Site (WETS), conduct a market study of available ROV solutions, purchase an ROV to support University of Hawai‘i, Department of Energy, and US Navy Research objectives at WETS, and, through use of the ROV, to conduct an analysis of the utility and limitations of that ROV in support of wave energy test objectives.

The ROV will provide important research, maintenance and emergency response capabilities that are expected to greatly enhance the ability of the DOE and Navy at WETS.

Tasks under the Agreement for Services include:

- Task 001: Requirements Assessment
- Task 002: Market Study of Available ROVs
- Task 003: ROV Procedural Analysis
- Task 004: ROV Purchase
- Task 005: ROV Installation Aboard Site-Dedicated Support Vessel
- Task 006a: ROV Operational Assessments Report #1
- Task 006b: ROV Operational Assessments Report #2
- Task 006c: ROV Final Report

This report presents the results of Task 006a – ROV Operational Assessments Report #1.

2. PROJECT LOCATION

ROV studies and operations are based on work anticipated at the Kāneʻohe Marine Corps Base (MCBH) Wave Energy Test Site (WETS). The Wave Energy Test Site is located on the windward side of the Island of Oʻahu, offshore of the Kāneʻohe Marine Corps Base Hawaiʻi. The test site is located northeast of Heʻeia Kea Small Boat Harbor within the security zone of MCBH. Key features at WETS, including the 30-meter test site, deep water wave energy test sites (comprised of 60 meter and 80 meter berths), Heʻeia Kea Small Boat Harbor, Dedicated Vessel Approved Mooring Area, Pyramid Rock, Battery French and the MCBH Fuel Pier, are shown in Figure 2-1.

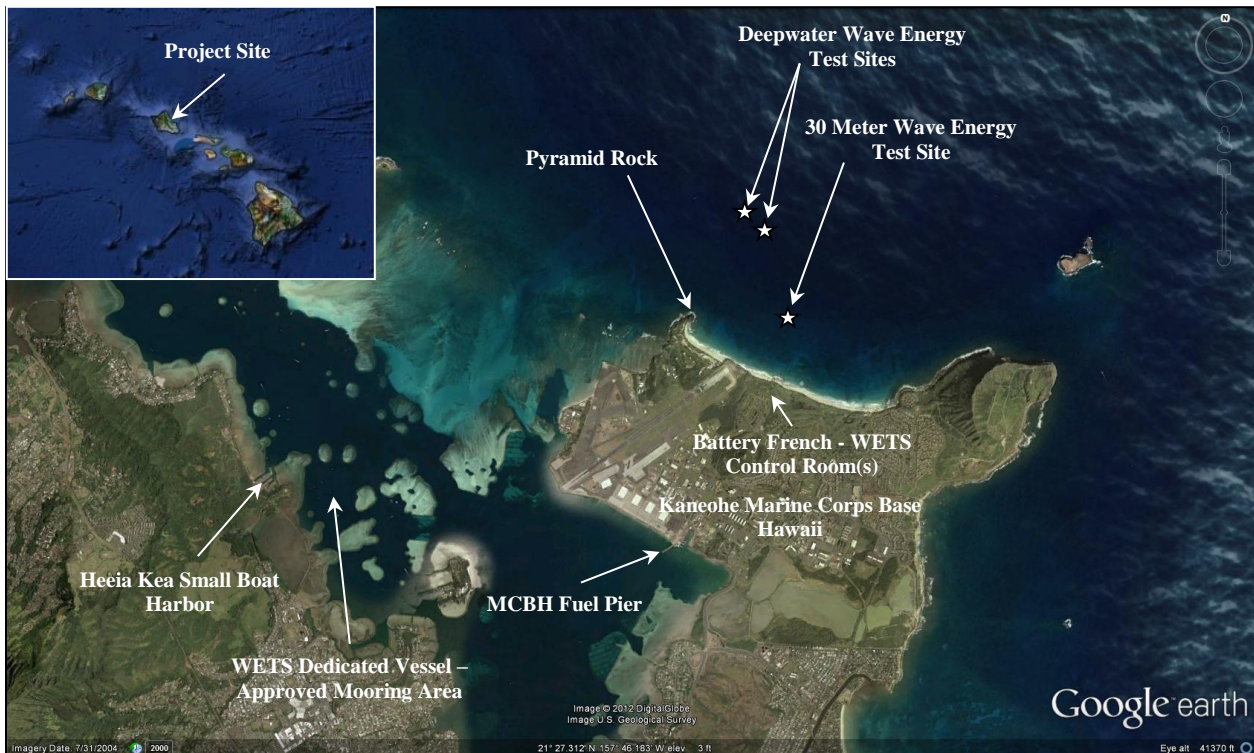

Figure 2-1. Kāneʻohe Marine Corps Base Hawaiʻi – Wave Energy Test Site

3. SUPER MOHAWK OPERATIONAL ASSESSMENT

SEI conducted installation operations for the ROV in early November 2017. The installation was completed in two phases, (1) dry testing of the ROV and its components at SEI's Nimitz offices, and (2) wet testing onboard the Huki Pau alongside Pier 26 in Honolulu Harbor. Through the wet and dry testing items to improve upon, modify, or replace were identified. Below is a of these items:

- Develop documentation procedures for maintenance and modification operations, as well as, pre-dive, dive, and post-dive logs.
- Remove the A-frame and level wind of the winch as they will not be used to lift the ROV.
- Replace the fixed junction box on the winch.
- Modify the rotating junction box on the winch to allow for servicing with the tether on.
- Update ROV control software (SubCan) to make use of the bear paw controls.
- Re-termination of the fiber optics and electrical connectors on the tether and spare tether.

Additionally, there were modifications requested by FORUM to the deck cable connections. This report will cover the documentation and A-frame removal from the winch.

3.1 Documentation Procedures

SEI has created templates for Dive Logs, Maintenance Logs, and Modification Logs. These templates are a standardized means to document operations of the ROV. A sample dive log from the first super mohawk dive is shown in Figure 3-1. The maintenance logs are to help document the standard upkeep of the ROV (oil changes, compensator filling, etc.). A maintenance log for damage to the compass connector is shown in Figure 3-2. The Modification Logs used to document the modifications to the ROV and associated equipment that are intended to be permanent. The Modification Log concerning the deck cable wiring is given in Appendix I: Modification Report. Finally, the

The pre-dive and post-dive activities are critical to ensuring successful operation of the ROV. The Pre-dive checklist is the primary list of checks and tasks to be completed prior to the operation of the ROV. It included checks prior to powering up the ROV and systems test after the power up. The Pre-dive checklist is shown in Appendix II: Pre-dive Checklist. Following the dive operations, the Post-dive checklist is used to confirm that there was damage sustained to the ROV and to protect damage from occurring while storage.

Prior to the Pre-dive, the electrical and fiber connections of the ROV need to made-up. The checklist/procedure for these connections is in given in Appendix IV: Electrical Connections Checklist.

All documentation concerning the ROV has been incorporated into a OneNote data base. This means that it can be shared between all personnel. Also, it can be used by clients to integrate their systems into the existing Super Mohawk infrastructure.

Dive Log #001



Date:	11/14/2017
Job Number:	N/A
Project Name:	ROV Testing
Project Location:	Honolulu Harbor Pier 26

Personnel:

Weather Conditions:

Pilot:	P. Anderson	Wind Speed and Direction:	Calm
Navigator:	Ben Jones, Forum	Wave height and Direction:	0
Winchman:		Current Speed and Direction:	0
Captain:	A. Basket	Visibility:	6-8ft
Others:	K. Kohnfelder, E. Crumpton		

Equipment Used:	Huki Pau, Cable cutter, cutting wheel, right manipulator,
------------------------	---

Dive Notes:

Checked ballast and added lead to compensate for the modified floatation. Lead was added to the aft of the ROV.

Checked camera function. Good.

Checked operation of the cable cutter and cutting wheel. Good.

Dialed in the auto functions of the ROV, auto heading, auto depth, auto-altitude. Auto-depth was particularly hard to configure. Finally, the appropriate settings were achieved to allow the ROV to maintain a near constant depth.

Figure 3-1 Dive Log

#001 Compass Connector Maintenance Report

Date of Modification:	11/20/2017
Previous Dive Number:	000
Personnel:	P. Anderson, Ben Jones (FORUM)



Maintenance Notes:

A chip on the edge of the compass connector was found prior to the work starting on the ROV.

Forum has agreed to send a new connector to replace this broken one.

The replacement of the connector is very technical requiring work in the pod. It was discussed and the decision was made to leave the chipped connector in place and monitor the damage.

Report Number:	001
-----------------------	------------



UPDATE:

A replacement connector was supplied from FOURM. It is in the spares and cable box.

Figure 3-2 Maintenance Log

3.2 Deck Winch Modifications

SEI purchased a used third-party deck winch to support ROV operations. The winch came with an A-frame and level wind system that was not needed with the free-swimming arrangement of the Super Mohawk. The design of the ROV is such that the tether should only carry its own weight/drag and not designed to handle the weight of the ROV in the air. Lifting of the ROV can only be conducted with the latch lock and crane. The extended winch base that acted as the A-frame mount was removed and the forklift pockets shifted. Lifting pad-eyes were installed. The modified deck winch with the tether removed is shown in Figure 3-3.



Figure 3-3 Deck Winch

4. SUMMARY

SEI developed standardized means to document the maintenance and modifications of the ROV. Likewise, a Pre-dive and Post-dive checklists were compiled to identify problems out of the water. Modification Reports allow personnel to understand the changes to the original “as built” condition. Maintenance Reports provide a procedure of the standard maintenance of the ROV.

The removal of the deck winch A-frame and level wind system will save space on the deck of the *Huki Pau* or the *Kūpa ‘a*. This will be critical for lifting operations with either vessel.

The Super Mohawk ROV is operational, and can be currently utilized from SEI’s vessel, *Huki Pau* or another vessel of opportunity should the need at WETS arise. Once shipbuilding operations on-board *Kūpa ‘a* are complete, the Super Mohawk ROV will be loaded and tested on-board the WETS dedicated vessel as well.

5. APPENDIX I: MODIFICATION REPORT

#001 Deck Cable Connection at SCU Modification Report

Date of Modification:	3/8/2018
Previous Dive Number:	001
Personnel:	P. Anderson



Maintenance Notes:

Report Number:	001
-----------------------	------------

The modification of the wiring for the deck cable is documented in the following email:

“Aloha Patrick and Andrew,

I trust you are both well.

Patrick I have some information on your deck cable connections between the Surface control unit and the Fixed JB on the winch.

Please use this file share link to download an amended copy of the manual.

<https://fet.sharefile.com/d-sd10aa8c96044df89>

In particular it is the new long line drawing that I would like to draw your attention to. E141-891-001

Also please see E141-325-017 for the SCU wiring diagram (page 1).

If you cast your mind back to the FAT we were seeing high current draw during the endurance test.

An additional wire was added per phase on the deck cable connections to overcome this but unfortunately the manual set was not updated to include this wiring change. This meant during my visit I was working from an earlier revision drawing.

On the new 891 long line drawing you can now see the additional wire per phase. This explains why there were 3 wires in the SCU/deck cable connector that I removed (along with 4 wires for the TMS 3phase and neutral) due to the fact they were not on the long line drawing and we had them down as being earthed out in the Winch JB. As you would for unused cables.

You will need to reconnect wires 17, 18, 19 and 20 back into the deck cable connector (CN1) at the SCU.

Leave wires 28-31 for the TMS unconnected. (page 1 E141-325-017)

You are now going to need to modify your Winch JB terminal rail with 4 more terminal connections. One on each phase and one for the neutral. You will also need to fit new jumper links to join up the additional terminal respectively.

Locate wires 17, 18, 19 and 20 in the winch JB and terminate them according to there relative phase.

I hope this all makes sense. If you need any further assistance, please drop my a reply and I will get back you as fast as I can. Or give me a call, you have my number.

Best regards,

Ben Jones.
Systems Integration Technician.

FORUM ENERGY TECHNOLOGIES (UK) LTD trading as FORUM SUBSEA TECHNOLOGIES

Ings Lane, Kirkbymoorside, York, North Yorkshire, YO62 6EZ.

+44 (0)1751 431751 [main] +44 (0)1751 434142 [d] +44 (0)7812 678489 [m] +44 (0)1751 431388 [f]

ben.jones@f-e-t.com

www.f-e-t.com “

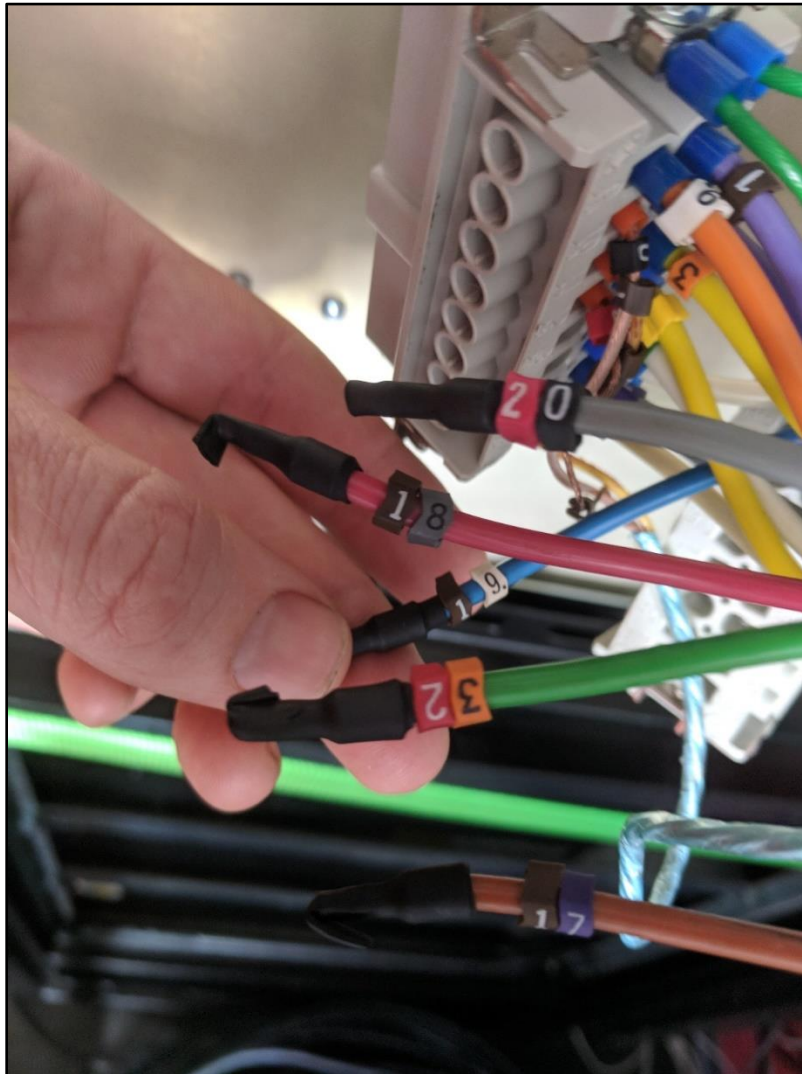

The original setup:
Wire 17, 18, 19, 20
and 32 were
disconnected by
Ben Jones
(FOURM) and heat
shrink capped.

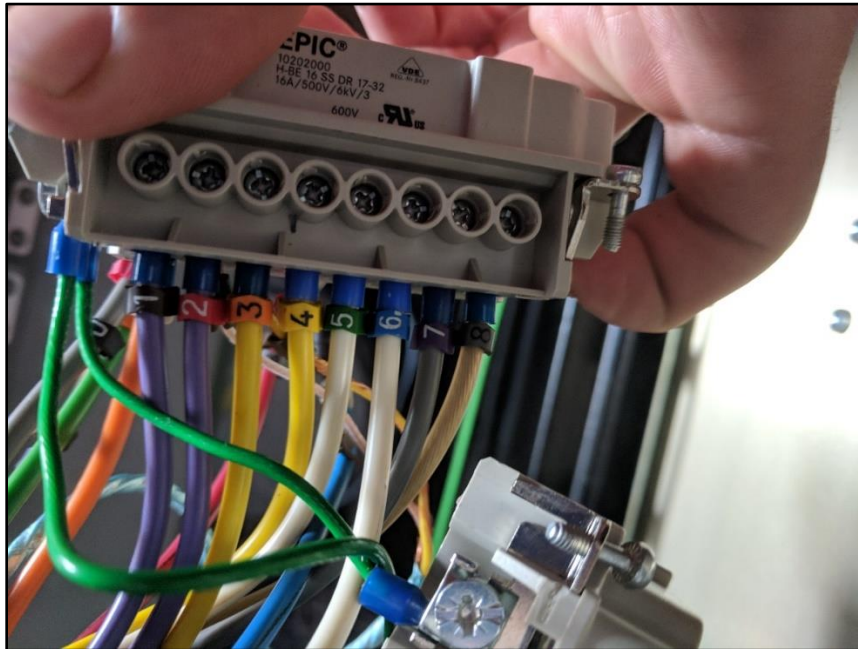

Wiring on the inside the deck cable connector.

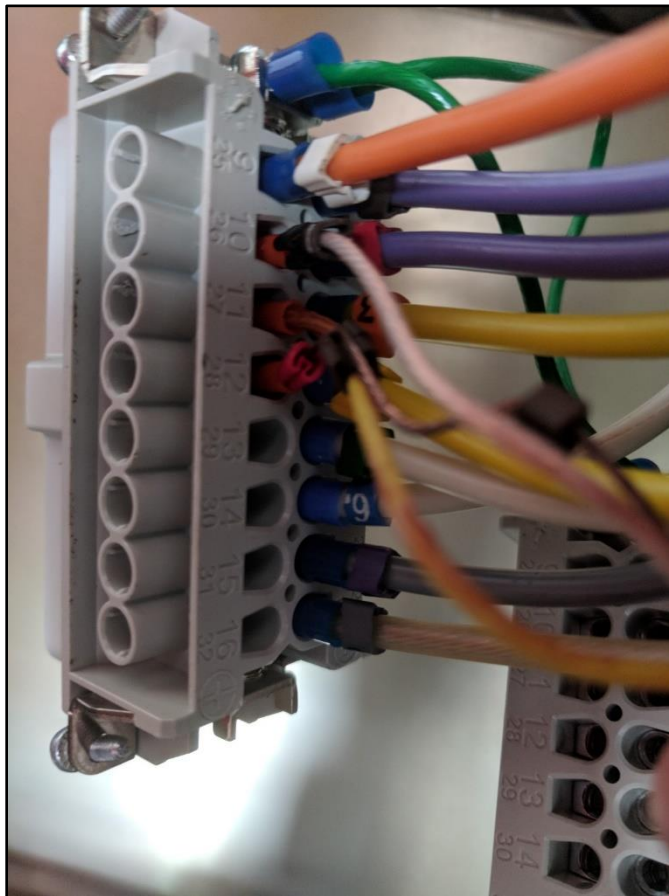

More wiring on the other side the deck cable connector.

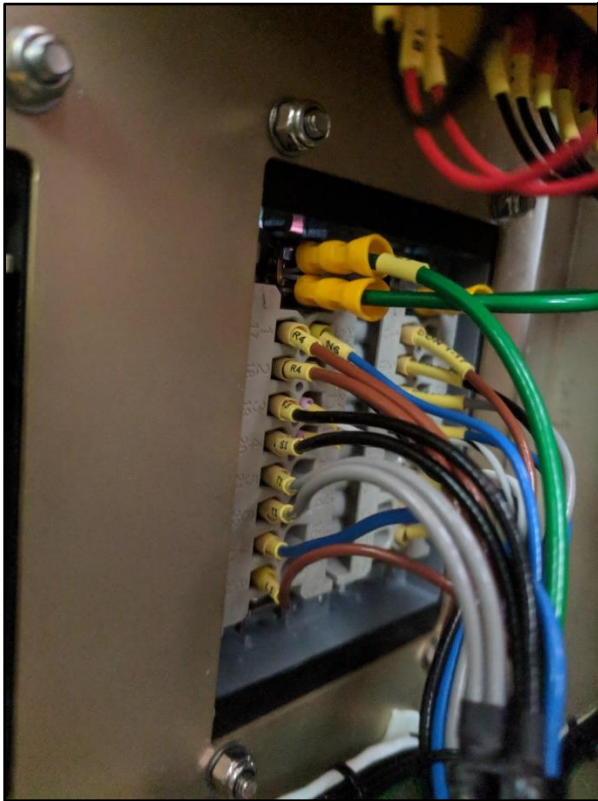

This is the connector viewed from inside the

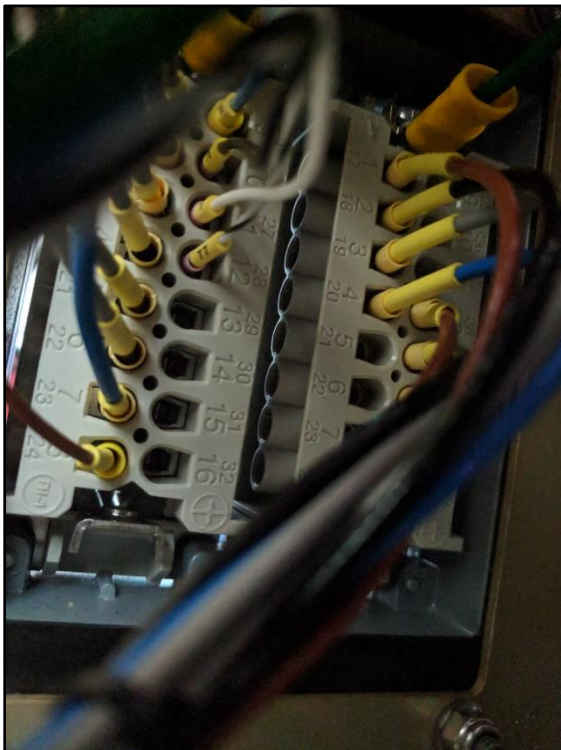

Note the four wires in the 17-20 slots. These are the additional wires that were added to help with the High current draw in the email. These are the ones that were disconnected and capped previously in error.

17 - brown
18 - black
19 - grey
20 - blue

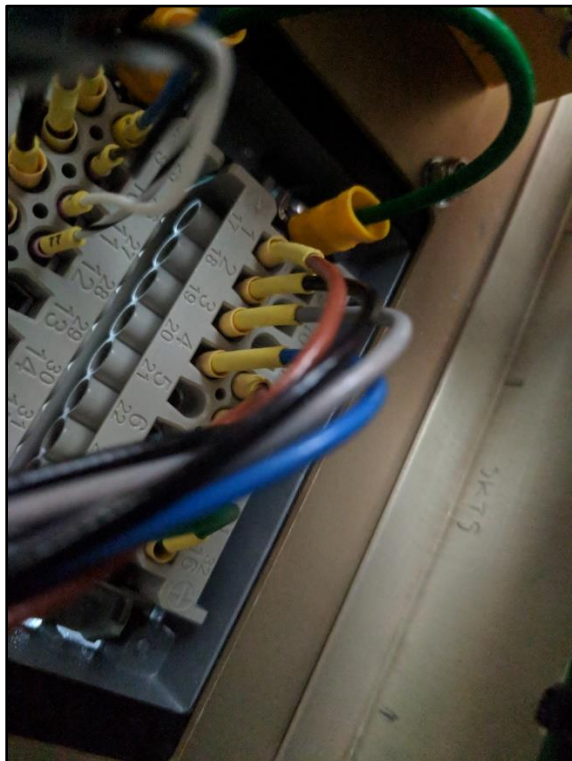

In addition to the four wires 17-20, wire 32, the grounding wire was connected.



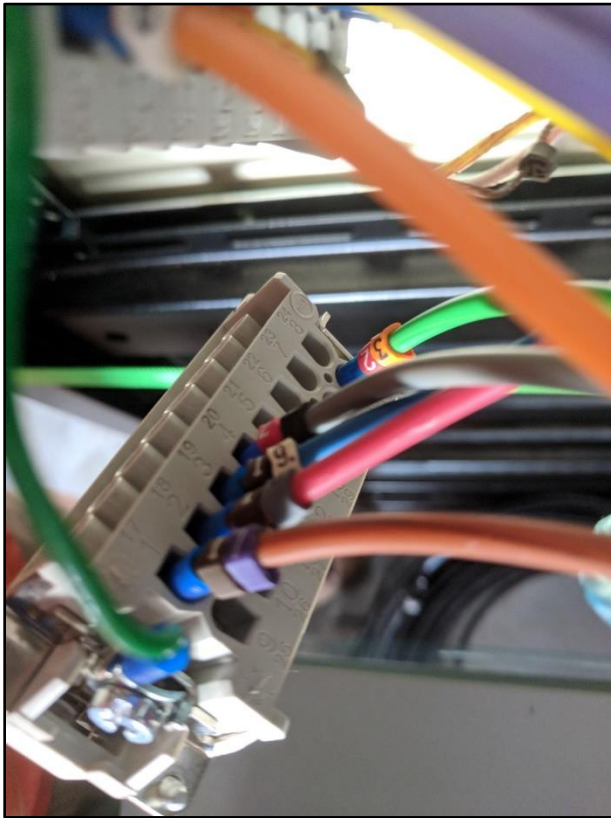

Wires 17-20 and 32 connected into the second plug.



Completed connection wiring

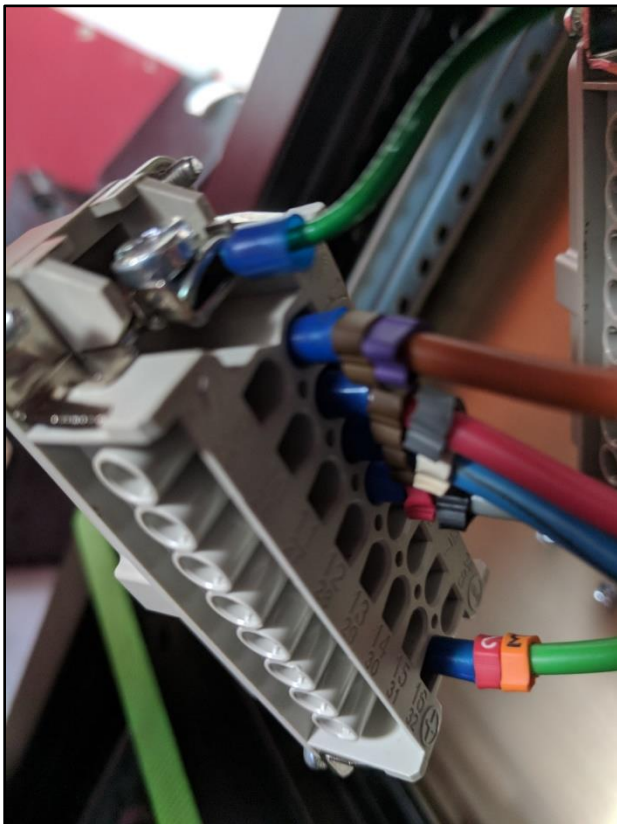
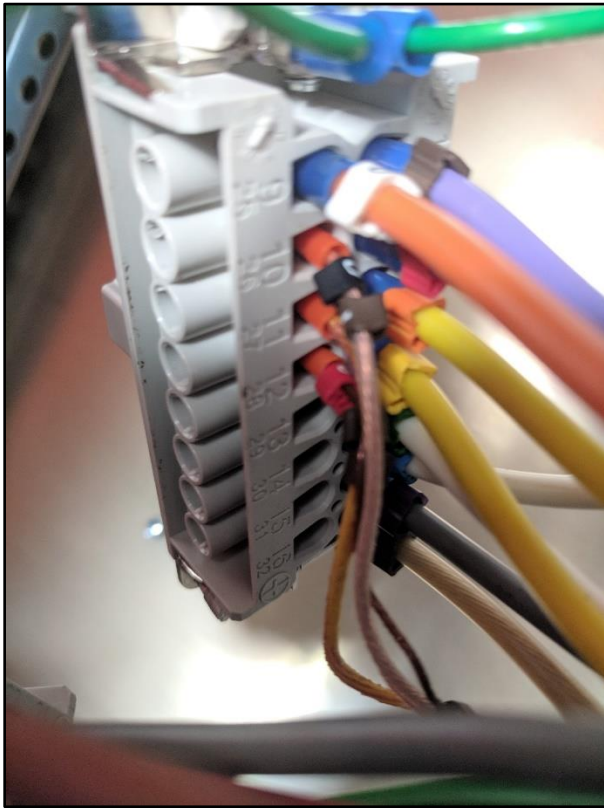

6. APPENDIX II: PRE-DIVE CHECKLIST

ROV Pre-Dive Checklist



Date:		Dive Number:	
Job Number:		Operator:	
Project Name:		Start time:	
Project Location:		Stop time:	

Before Turning on ROV:

- Make sure all air has been bled from the transformer/junction boxes and compensators
- Check that the thruster compensator and transformer box is fully charged, and all the isolation valves are open.
- Check that the compensators on the pan & tilt and tilt units are fully charged
- Check to confirm oil compensators have correct amount of oil
- Confirm oil compensators are open
- Check all oil-filled systems for leaks, thrusters and comps etc.
- Check compensators for any additional equipment that may have been fitted.
- Make sure transponder is connector is plugged in
- Make sure that all connector cables are secure and are well clear of the thrusters
- Ensure all unused vehicle connectors are capped securely with dummy plugs.
- Confirm there is no debris in the thrusters
- Inspect Collection Skid for debris in bio box or bottles
- Make sure lens cap is off
- Check that the Vehicle Buoyancy is bolted to the frame.
- Make sure umbilical is stretched out on deck
- Check for tether scrapes, nicks, or other visible damage.
- USBL (underwater acoustic positioning)
 - Secure hydrophone pole to ship
 - Secure hydrophone to pole
 - Clean and lubricate the connector on subsea end of the hydrophone cable
 - Mate hydrophone cable to hydrophone
 - Plug Tracking console power plug into proper AC power source
- Make sure the generator has enough fuel to support the operation
- Start Generator (generator start-up procedure can be found on the side of the generator)

Turning on ROV:

- Check that personnel are clear of the ROV then switch On ROV power and Thruster power.
- Check that all thrusters operate in the correct direction when given the appropriate commands from the pilot's joystick.
- Confirm auto thruster motion buttons are not pressed
- Confirm communications between SubCAN and vehicle
- Power on Mini-Zeus topside after ROV
- Test zooming function of Mini-Zeus
- Take digital stills with Kongsberg software
- Make sure all recording devices (tapes, DVDs, CDs) are labeled and ready to record
- Test lights
- Test both sets of lasers
- Ensure lights and lasers are off
- Check pan & tilt unit
- Check all manipulator functions (if fitted).
- Check that the sonar is functioning and communicating with the surface control unit.
- Check that line insulation monitors are clear, and no alarms are present on the SCU and hand control unit.
- Test Collection Skid Functions: Manipulator, bio box, carousel
- Notify bridge/captain that ROV is ready to go in the water.
- Notify the bridge/captain when ROV is hoisted
- Notify bridge/captain when ROV is in the water

Notes:

7. APPENDIX III: POST-DIVE CHECKLIST

ROV Post-Dive Checklist



Date:		Dive Number:	
Job Number:		Operator:	
Project Name:		Start time:	
Project Location:		Stop time:	

- Complete a Dive log
- Rinse the ROV
- Visually inspect the ROV to ensure to physical or mechanical damage has occurred.
- Check propellers for any fouling
- Visually check the ports to ensure that no water has entered the camera, thruster, or electronics housings.
- Test lights and confirm off
- Check pan & tilt unit
- Check all manipulator functions (if fitted).
- Make sure all air has been bled from the transformer/junction boxes and compensators
- Charge the thruster compensator and open all the isolation valves
- Charge the compensators on the pan & tilt units
- Charge the transformer box compensator
- Check to confirm oil compensators have correct amount of oil
- Confirm oil compensators are open
- Check all oil-filled systems for leaks, thrusters and comps etc.
- Check compensators for any additional equipment that may have been fitted.
- Make sure transponder is stored in the appropriate container
- Make sure that all connector cables are secure and are well clear of the thrusters
- Confirm there is no debris in the thrusters
- Inspect Collection Skid for debris in bio box or bottles
- Put lens cap on
- Put hydrophone in its storage container
- Clean and lubricate the connector on subsea end of the hydrophone cable
- Put Tracking console away in the proper storage container
- Turn generator off (generator shut-down procedure can be found on the side of the generator)
- Check for tether scrapes, nicks, or other visible damage.
- Clean all components of the ROV and ensure that there is no build-up on the connectors
- Store the tether and vehicle properly for the next use.

Notes:

8. APPENDIX IV: ELECTRICAL CONNECTIONS CHECKLIST

ROV Electrical Connections Checklist



Date:		Dive Number:	
Job Number:		Operator:	
Project Name:		Start time:	
Project Location:		Stop time:	

Checklist:

- Check that the main power switch on the console is off, ROV circuit breaker is off
- Check all power leads to the Isolation Transformer and Surface Control Console are connected and intact.
- Secure Chinese finger to hook on vehicle
- Wire inside of ROV junction box via procedure
- Hook fibers from junction box up after all other wiring is finished
- Connect transformer to SCU
- Check that all ROV umbilical connectors are secure and in good condition.
- Confirm USBL Transponder is on and charged
- Check that there is no debris, tools etc. in ROV.
- Check all personnel are clear of the vehicle thrusters etc.
- Apply the 230VAC supply to the surface control system. Power should now be available to the video monitors, video recorders and the sonar processor. The power off switches should also be illuminated on the SCU.
- Plug the remote hand controller into the SCU. The Power LED should be illuminated this is an indication that power is being supplied to the hand controller.
- Test the earth fault monitoring system by holding in the test button for about five (5) seconds. The alarm will sound, and the fault indicator will be illuminated. The ohms meter should indicate a fault of about 10K ohms. Power will be lost to the vehicle.
- Power and Thruster Power switches. Press the Mute Button, this will silence the alarm, but the fault indicator will remain. Operate the override key switch, the power OFF switches should re-illuminate indicating that the system has been overridden. Hold in the Reset Button for 3-4 seconds then release, this will reset the earth fault. After testing, reset everything to OFF.
- Ensure the input line voltage matches the setting in the isolation transformer
- Apply power to the ROV isolation transformer and close the two circuit breakers. The volt meters on the main SCU should indicate two voltages, 240V vehicle power, and 440V Thruster drive power.
- Before switching on the ROV power, check that personnel are clear of the vehicle, then apply power to the ROV.

- Switch on the ROV 240VAC power, the flashing communications LED should become steady once telemetry with the vehicle has been established. Switch on the cameras.
- After 2 or 3 seconds, video pictures should appear on the video monitors.
- With all power switched on, test the line insulation monitor. Pressing the test button on the main SCU will kill power to the ROV. Reset the LIM system and turn the ROV power back on again.
- Check the Telemetry link between the console and the vehicle by operating the camera tilt unit. The tilt unit should move, and the tilt angle should change on the video overlay display.
- Operate the vehicle lights. They should all be dimmable from the pilot's console.
- Once Telemetry has been established, check that personnel are clear of the vehicle, switch on the Thruster Power.

Notes:

APPENDIX VII: INTERIM OPERATIONAL ASSESSMENT #2

University of Hawai'i Office of Research Services: Asia-Pacific Research Initiative for Sustainable Energy Systems 2012

**Wave Energy Testing
Task 006B: ROV Operational Assessments Report #2**

Kāneʻohe Marine Corps Base, Oʻahu , Hawai'i



Prepared for:

University of Hawai'i Office of Research Services:
Asia-Pacific Research Initiative for Sustainable
Energy Systems 2012

Prepared by:

Sea Engineering, Inc.
863 N. Nimitz Hwy
Honolulu, HI 966817
Job No. 13001



Table of Contents

1. INTRODUCTION	4
2. PROJECT LOCATION	5
3. SUPER MOHAWK OPERATIONAL ASSESSMENTM AND MODIFICATONS.....	6
3.1 FIXED JUNCTION BOX MODIFICATION (REPLACEMENT).....	6
3.2 ROTATING JUNCTION BOX MODIFICATION.....	6
3.3 UPDATING THE SUBCAN SOFTWARE	9
3.4 USBL SOFTWARE INSTALLATION	9
4. SUMMARY	19
5. APPENDIX I: FIXED JUNCTION BOX TERMINATION.....	20
6. APPENDIX II: ROTATING JUNCTION BOX TERMINATION	24
FIGURE 2-1. KĀNE‘OHE MARINE CORPS BASE HAWAI‘I – WAVE ENERGY TEST SITE	5
FIGURE 3-1. FIXED JUNCTION BOX MODIFICATION	7
FIGURE 3-2. ROTATING JUNCTION BOX MODIFICATION	8
FIGURE 3-3 SCHILLING ROBOTICS BEAR PAW	9
FIGURE 3-4 EASYTRACK USBL SYSTEM SPECS 1	11
FIGURE 3-5 EASYTRACK USBL SYSTEM SPECS 2.....	12
FIGURE 3-6 TRANSPONDER SPECS (1019) 1	13
FIGURE 3-7 TRANSPONDER SPECS (1019) 2	14
FIGURE 3-8 EASYTRACK LITE COMMUNICATIONS SETUP	15
FIGURE 3-9 EASYTRACK LITE MAP DISPLAY	16
FIGURE 3-10 HYPACK HARDWARE SETTINGS	17
FIGURE 3-11 HYPACK MAP DISPLAY	18
FIGURE 3-12 HYPACK DATA DISPLAY	18

1. INTRODUCTION

In support of the University of Hawai‘i’s Project “Asia-Pacific Research Initiative for Sustainable Energy Systems 2012 (APRISES12), Task 4.2, “Wave Energy Testing”, Sea Engineering Inc. (SEI) was contracted to assess remotely operated vehicle (ROV) requirements at the U.S. Navy Wave Energy Test Site (WETS), conduct a market study of available ROV solutions, purchase an ROV to support University of Hawai‘i, Department of Energy, and US Navy Research objectives at WETS, and, through use of the ROV, to conduct an analysis of the utility and limitations of that ROV in support of wave energy test objectives.

The ROV will provide important research, maintenance and emergency response capabilities that are expected to greatly enhance the ability of the DOE and Navy at WETS.

Tasks under the Agreement for Services (MA150044) include:

- Task 001: Requirements Assessment
- Task 002: Market Study of Available ROVs
- Task 003: ROV Procedural Analysis
- Task 004: ROV Purchase
- Task 005: ROV Installation Aboard Site-Dedicated Support Vessel
- Task 006A: ROV Operational Assessments Report #1
- Task 006B: ROV Operational Assessments Report #2
- Task 006C: ROV Final Report

This report presents the results of Task 006B – ROV Operational Assessments Report #2.

2. PROJECT LOCATION

ROV studies and operations are based on work anticipated at the Kāneʻohe Marine Corps Base (MCBH) Wave Energy Test Site (WETS). The Wave Energy Test Site is located on the windward side of the Island of Oʻahu, offshore of the Kāneʻohe Marine Corps Base Hawaiʻi. The test site is located northeast of Heʻeia Kea Small Boat Harbor within the security zone of MCBH. Key features at WETS, including the 30-meter test site, deep water wave energy test sites (comprised of 60 meter and 80 meter berths), Heʻeia Kea Small Boat Harbor, Dedicated Vessel Approved Mooring Area, Pyramid Rock, Battery French and the MCBH Fuel Pier, are shown in Figure 2-1.

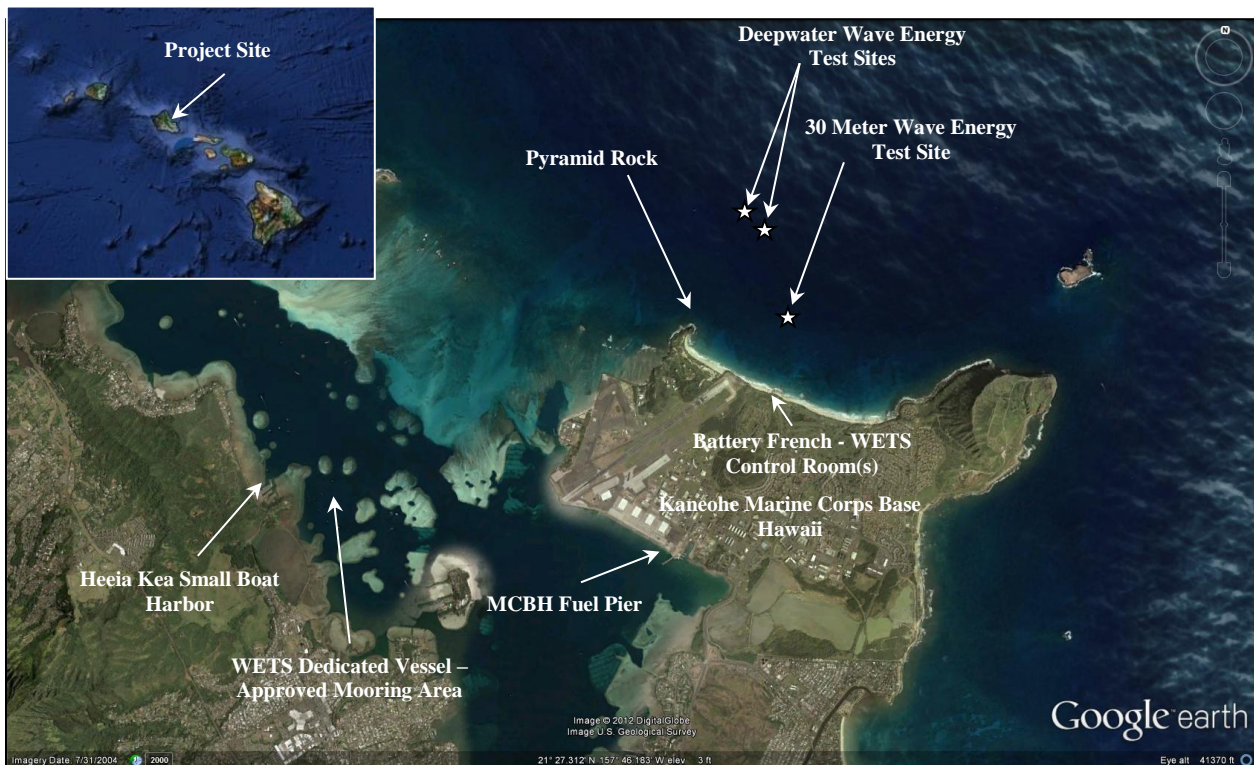

Figure 2-1. Kāneʻohe Marine Corps Base Hawaiʻi – Wave Energy Test Site

3. SUPER MOHAWK OPERATIONAL ASSESSMENT AND MODIFICATIONS

SEI conducted installation operations for the ROV in early November 2017. The installation was completed in two phases, (1) dry testing of the ROV and its components at SEI's Nimitz offices, and (2) wet testing onboard the Huki Pau alongside Pier 26 in Honolulu Harbor. Through the wet and dry testing items to improve upon, modify, or replace were identified. Below is a list of these items:

- Develop documentation procedures for maintenance and modification operations, as well as, pre-dive, dive, and post-dive logs.
- Remove the A-frame and level wind of the winch as they will not be used to lift the ROV.
- Replace the fixed junction box on the winch.
- Modify the rotating junction box on the winch to allow for servicing with the tether on.
- Re-termination of the fiber optics and electrical connectors on the tether and spare tether.
- Update ROV control software (SubCan) to make use of the bear paw controls.
- Install USBL software and vessel tracking software.

SEI has created templates for Dive Logs, Maintenance Logs, and Modification Logs. These templates were included in the first Operational Assessment Report, along with the Pre and Post Dive check list. The modifications to the deck winch were also included in the first Operational Assessment Report.

3.1 Fixed Junction Box Modification (Replacement)

The changes to the fixed junction box are documented in the 002 Fixed Junction Box Modification Report (Figure 3-1) and the Procedure for the termination of the Junction Box (Appendix I: Fixed Junction Box Termination).

3.2 Rotating Junction Box Modification

The rotating junction box inside the drum of the winch was too large to remove from the winch drum with the tether on. The height of the junction box was reduced by cutting out about 1.5 in from the walls and rewelding the two sections together. The shallower junction box allows for the removal with the tether in place, eliminating the need to remove the tether from the drum to access the junction box. This modification will reduce in-field troubleshooting and repairs. The modification report for the rotating junction box is shown in (Figure 3-2). Appendix II: Rotating Junction Box Termination shows the procedure for connecting the slip ring wiring to the tether.

The fiber optic connections to the ROV in the rotating and fixed junction boxes were re-terminated during the modifications. This was done to repair broken terminations as well as modify the length of the terminations. Completing these terminations the tether now has one fiber for the ROV communications (HD Video, ROV comms, etc.) and one for the external survey equipment. There is also to functional spare fibers.

#003 Fixed Junction Box Modification Report

Date of Modification:	5/1/2018
Previous Dive Number:	001
Personnel:	P. Anderson



Modification Notes:

Report Number:	003
----------------	-----

The size of the fixed junction box was too small which made working in the box difficult. The deck cable has a large number of wires that need to be grounded as well. The smaller fixed JB was replaced with a larger one from Industrial Electronics. A new layout of the box has all the ROV connections (440v 3-phase, 240v 1-phase, and CP Probe) on one side and all the grounded connection on the other. The changes to wiring of the 3-phase thruster supply in the previous modification report (002) are supported by the new layout. The spade connectors were removed and replaced with crimped ferrules. The picture below shows the final layout. More details can be found in the Procedure: Fixed Junction Box Termination.



Figure 3-1. Fixed Junction Box Modification

004 Rotating Junction Box Modification Report

Date of Modification:	5/1/2018
Previous Dive Number:	001
Personnel:	P. Anderson

Modification Notes:

The rotating junction box inside the drum of the winch was too large to remove from the winch drum with the tether on. The height of the junction box was reduced by cutting out about 1.5 in from the walls. The two sections were then welded together. The shorter junction box allows for the removal with the tether in place. Otherwise the tether would have to be stored on the deck of the vessel for access to the junction box.



Report Number: 004



Old Rotating Junction Box, does not fit with the lid and hardware installed.

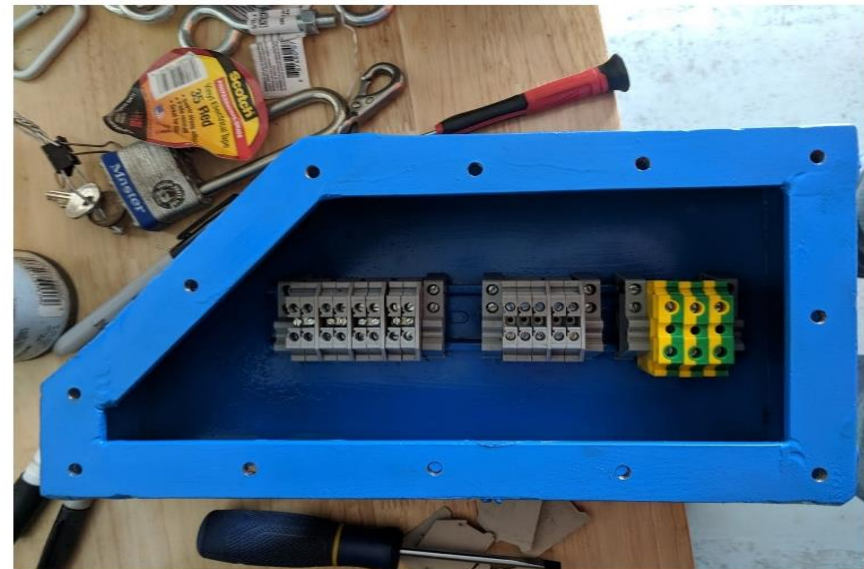

Modified Junction Box

Figure 3-2. Rotating Junction Box Modification

3.3 Updating the SubCan Software

The SM 36 control software was updated to allow the use of the bear paw controller for the second manipulation functions. Originally the operation of the second manipulator hydraulics functions are spread across two pages of the Subcan control software, which produced an inefficient operation when using the second manipulator. Integration of the bear paw controller allows for manipulator functions to be conducted without interaction through the Subcan software on the computer screen. An image of the bear paw is shown in Figure 3-3.



Figure 3-3 Schilling Robotics Bear Paw

3.4 USBL Software Installation

The SM 36 ROV will be tracked with an Ultra Short Base Line (USBL) underwater positioning and tracking system which uses acoustics to calculate a range and bearing to the transponder from the transducer. SEI has a system to track the inspection class ROV from Applied Acoustic Engineering. The system consists of the Easytrack Lite rackmount console (model: 2661) and transducer (model: ETM902C). The SM36 was purchased with a model 1019 transponder. The EasyTrack specifications are shown below in Figure 3-4 and Figure 3-5. The specifications for model 1019 transponder are shown in Figure 3-6 and Figure 3-7. The transponder is powered by

an internal battery, thus the transponder can continue to provide the position of the ROV if communication is lost due to a tether cut or electrical short.



Easytrak Lite USBL System

- : Accurate and stable
- : Easy to operate
- : Tracks on the horizontal
- : Approved for military use

Easytrak Lite is an Ultra Short Baseline (USBL) underwater positioning and tracking system that has developed a solid reputation for reliable, positional accuracy and versatility.

The system consists of a transducer and cable, a 2U rack mounted console and operating software. The Easytrak Lite system is completed by one of Applied Acoustics' beacons attached to the target object, though up to 4 individually identified subsea targets can be positioned simultaneously.

Both the system itself and the accompanying software interface have been developed and refined for uncomplicated user-friendly operation, so that even a relatively inexperienced user can proceed very efficiently and with confidence.

The ETM902C transducer was designed specifically to be small and relatively heavy, allowing it to be suspended by the cable supplied with the system. Alternatively, a range of fittings are available for a variety of deployment methods, from a simple scaffold arrangement to a complex through hull gate valve based system.

Arranged inside the rugged transducer assembly is a multi element receive array and a single powerful omni-directional transmitter. A pitch, roll and magnetic

heading sensor is also included in the assembly, and factory calibrated to the transducer array. The factory corrections reside in the transducer electronics, and when connected to the Easytrak system, the corrections will automatically transfer to the software.

Easytrak Lite software is simple to use with an intuitive drop down menu and provides many facilities found in more costly systems. When in use with a GPS or similar system, the software will automatically calculate the UTM zone. As standard, the software can accept external pitch, roll & heading sensors.

Designed for 'dry ops' installation in a vessel's Operations Room, the 2U high 19" rack mount console unit supplied with the system connects directly to the transducer assembly using a single connection, and to a PC running Easytrak Lite software. This topside unit also contains DSP receive electronics and some of the transmit electronics. External sensors can be added via clearly marked connectors.

The flexibility of the Easytrak design allows it to detect a variety of underwater beacon types, including some of the Applied Acoustics' release beacons, and positioning beacons produced by other manufacturers.



Figure 3-4 Easytrack USBL System Specs 1



Technical Specification

EASYTRAK LITE CONSOLE, MODEL 2661

Size	19" Rackmount. 2U. 482 x 88 x 345mm
Serial communications	RS-232. USB to RS-232 adaptors available
Power requirements	90-250Vac at 50VA
PC requirements (min)	1.2GHz running Windows XP, Windows 7. USB or up to 3 x RS-232 port. Colour display, 1024 x 768. CD Rom drive
Data Output	AAE format, TP-2EC TP-EC W/PR, Simrad 300P, Simrad 309 (binary) \$PSIMSSB, \$PSIMSNS (One string after the other for each fix) \$GPRMC (Suitable for Coda Octopus 460P and others) KLEIN 3000, \$GPGGA and \$GPVTG. Internal data logging
Compass Input	TCM-2.X, SGB-HTDS, SGB-HTDt, \$HEHDT, \$HDHDM, \$HDHDT, \$HDHDC
VRU Input	TCM-2.X, \$HCXDR, TSS1
GPS / DGPS Input	NMEA; GLL, GGA, RMC
Sync. Input	TTL type 5 Volt pulse. Triggers on rising edge.
Responder Output	Positive 12V pulse 5ms long

TRANSDUCER, TYPE ETM902C

Aluminium-Bronze transducer. May be tilted by 20° for towfish tracking

Dimensions	375mm long x 100mm diameter
Weight	Transducer: 9.5kg in air, 7kg in water
Depth Rating	50 metres

TRANSDUCER CABLE

Diameter	12.8mm nominal
Colour	Yellow
Length (xx)	20 – 60m standard lengths available
Connectors	Supplied
SWL	20kg (Allows transducer to be deployed from cable)

ACCURACY/PERFORMANCE

(Accuracy is based on the correct speed of sound being entered, no ray bending and an acceptable S/N ratio)

Slant Range accuracy	10cm
Position accuracy, standard	1.40° drms. 2.5% of slant range. Acoustic accuracy excludes heading errors
Position accuracy, high	0.60° drms. 1.0% of slant range. Acoustic accuracy excludes heading errors
Bearing Resolution	0.1° displayed. Internally calculated to 0.01°
Heading sensor accuracy	0.8° rms standard; +/- 0.1° resolution/repeatability
Pitch/Roll sensor accuracy	+/- 0.2° rms; +/- 0.1° resolution/repeatability
Channels	4 channels displayed from 134 stored
Frequency Band (MF)	Reception 22 - 32kHz Transmission 17 - 26kHz
Tracking Beam Pattern	> Hemispherical
Beacon Types	Transponders, Responders and Pingers
Interrogation Rate	0.5 - 30 seconds or external key
Transmit Power	178/185/190dB software controlled
CE Marking	Externally assessed for immunity and emissions. Conforms to 89/336/EEC

Figure 3-5 Easytrak USBL System Specs 2



Applied Acoustic Engineering Ltd
 Marine House, Marine Park, Gapton Hall Road, Great Yarmouth, NR31 0NB, United Kingdom

1000 Series Mini Beacon



1000 Series Mini Beacons incorporate Applied Acoustics' proprietary Sigma acoustic protocols, proven for use with AAE's USBL tracking systems, other manufacturers' USBL systems operating with wide bandwidth transmissions, as well as those using 'narrow band' tone signalling.

With an industry standard 5-pin connector, the beacons are quick and easy to configure using the 1082 Smart Switch or 1083 Multi-Charger that also activate and monitor the charging of the battery pack.

Key Features

- AAE proprietary Sigma bi-directional spread spectrum technology
- Quick and easy configuration
- Directional or omni-directional beam pattern options available
- Externally configurable as transponder, responder or pinger
- High power option model to operate longer ranges
- Options for use with remote transducers

Applications

- General purpose tracking and positioning applications
- Static and dynamic operations e.g. ROV, sidescan sonar.

Technical Specification

MODEL TYPES – PHYSICAL SPECIFICATION

Housing material: Hard anodised aluminium, with clear protection sleeve and stainless steel cage

	Beam Pattern	SPL*	Survival Depth	Diameter	Length	Weight in air
1015	±45°	194dB	2000m	74mm	410mm	3.08kg/1.46kg
1015H High Power	±30°	196dB	2000m	74mm	410mm	3.08kg/1.46kg
1019	±90°	188dB	1500m	74mm	395mm	2.88kg/1.38kg
1022	±20°	202dB	4000m	95mm	418mm	5.03kg/2.75kg

*Effective SPL is 5dB less when used with iXBlue GAPS USBL systems.

ELECTRICAL SPECIFICATION

Battery

Battery type Rechargeable. NiMH as standard
 Listening life 60 days



Figure 3-6 Transponder Specs (1019) 1

1000 Series Mini Beacon Technical specification continued...

Operational life, AAE Spread Spectrum Dependent on pulse rate and operational mode
 1015: 150 hours at 1.0pps
 1015H: 100 hours at 1.0pps
 1019: 150 hours at 1.0pps
 1022: 100 hours at 1.0pps
 Operational life reduced when used with non AAE USBL systems.

Configuration

Transmit frequency range 24 - 33.5kHz
 Receive frequency range 17 - 31kHz
 Turnaround time 15/30/60/100ms dependent on channel selection
 Transmit pulse width 1.5/3.0/10ms dependent on channel selection

External Inputs

Connector type MCBH5M 5-way connector
 Responder key + 5 to 25 Volts
 External power 22 to 35 Vdc@80mA
 Charge Onboard fast charger for 3 hour charge, typical. Activated and monitored via 1082 Smart Switch or 1083 Multi-Charger

USBL COMPATIBILITY

AAE 1000 Series beacons use Tone, Chirp, MFSK, DSSS and FHSS as transmission/reception protocols, allowing cross-compatibility with many USBL systems, including:

AAE Nexus	Spread Spectrum systems
AAE Easytrak	All models, tone systems
iXBlue	GAPS USBL
Kongsberg	HPR/HiPAP
ORE/Edgetech	USBL
Sonardyne	USBL

OPTIONS

Compatibility with USBL systems not listed above

Non-rechargeable batteries (alkaline)

Toroidal beam pattern version, Model 1019T

Survival depth to 4000m

Remote transducer (supplied with Model BCN-1010 electronic bottle);
 RM90, omni-directional rated to 1500m. RM45, directional, rated to 2000m. Inter connect cable, 2m standard

Depth sensors 100m/300m/1000m/2000m/4000m (adds D suffix to model number)

Digital depth transmission when used with AAE Nexus USBL systems

Floataction collar



Due to continual product improvement, specification information may be subject to change without notice.
 1000 Series Mini Beacon/ March 2015
 ©Applied Acoustic Engineering Ltd.



Applied Acoustic Engineering Ltd

T +44(0)1493 440355
 F +44(0)1493 440720
 E general@appliedacoustics.com
 W www.appliedacoustics.com

Figure 3-7 Transponder Specs (1019) 2

The software for the Easytrak software was installed on the sonar computer along with the Hypack marine survey software. The Easytrak software allows for 4 transponders to be tracked simultaneously if needed (tracking divers and ROV in the same operation potentially). The Easytrak system uses a USB to 4 port serial converter to connect the required devices and to output the position string. The output string has been set to the TrackPoint II 2EC standard. This string is input into the Hypack software via a serial port. This is shown in Figure 3-8 in the Serial Printer Section. Note that the GPS position should be OFF. The software outputs the GPS position if the GPS is ON. The TrackPoint II 2EC standard requires that the output string contain the relative X, Y, and Z distances as opposed to the GPS coordinates.

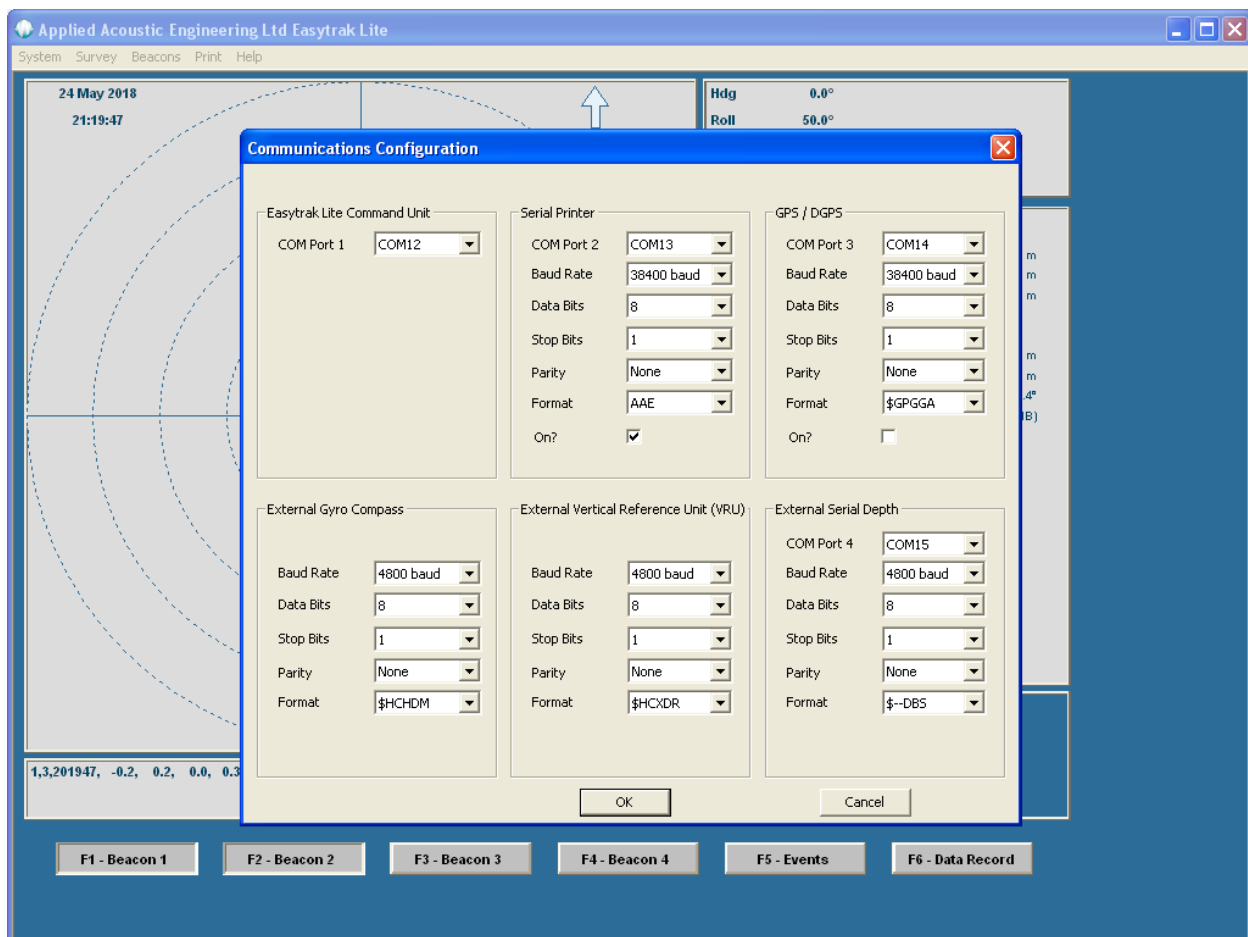

Figure 3-8 Easytrak Lite Communications Setup

The map display of the Easytrak software (Figure 3-9) shows the position of the transponder relative to the vessel and a few of the previous positions. The right side of the display shows the heading, pitch, and roll as well as the relative distances of each of the transponders being used.

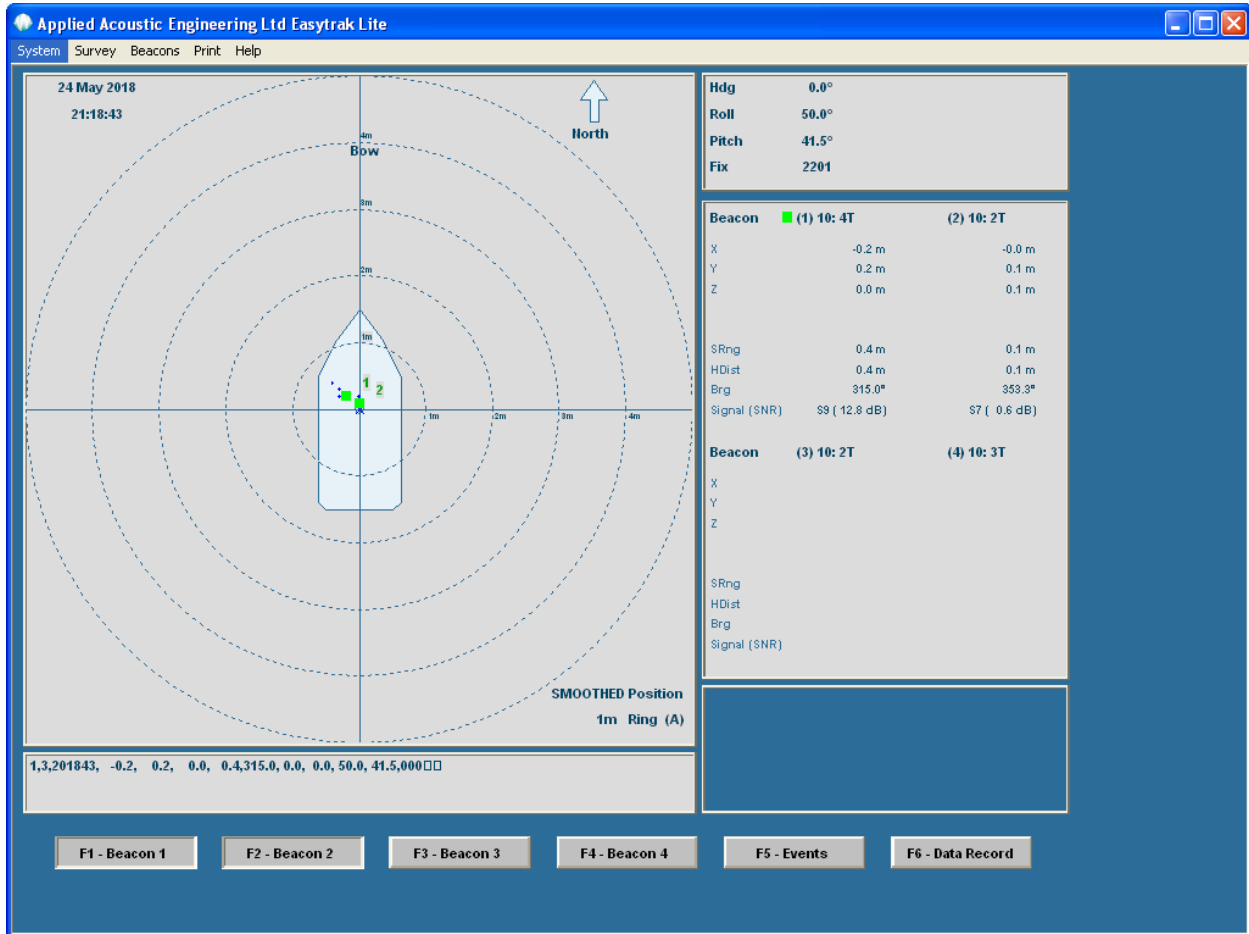

Figure 3-9 Easytrak Lite Map Display

The Hypack hardware settings are shown in Figure 3-10. The configuration has three vessels: Boat, ROV, and Mobile 2. The boats position is attained by a differential GPS. The position of the ROV and Mobile 2 are attained from the output string from the Easytrak Lite software. Both the ROV and Mobile 2 are defined by the Trackp.dll device. The first number of the output string is number of the beacon.

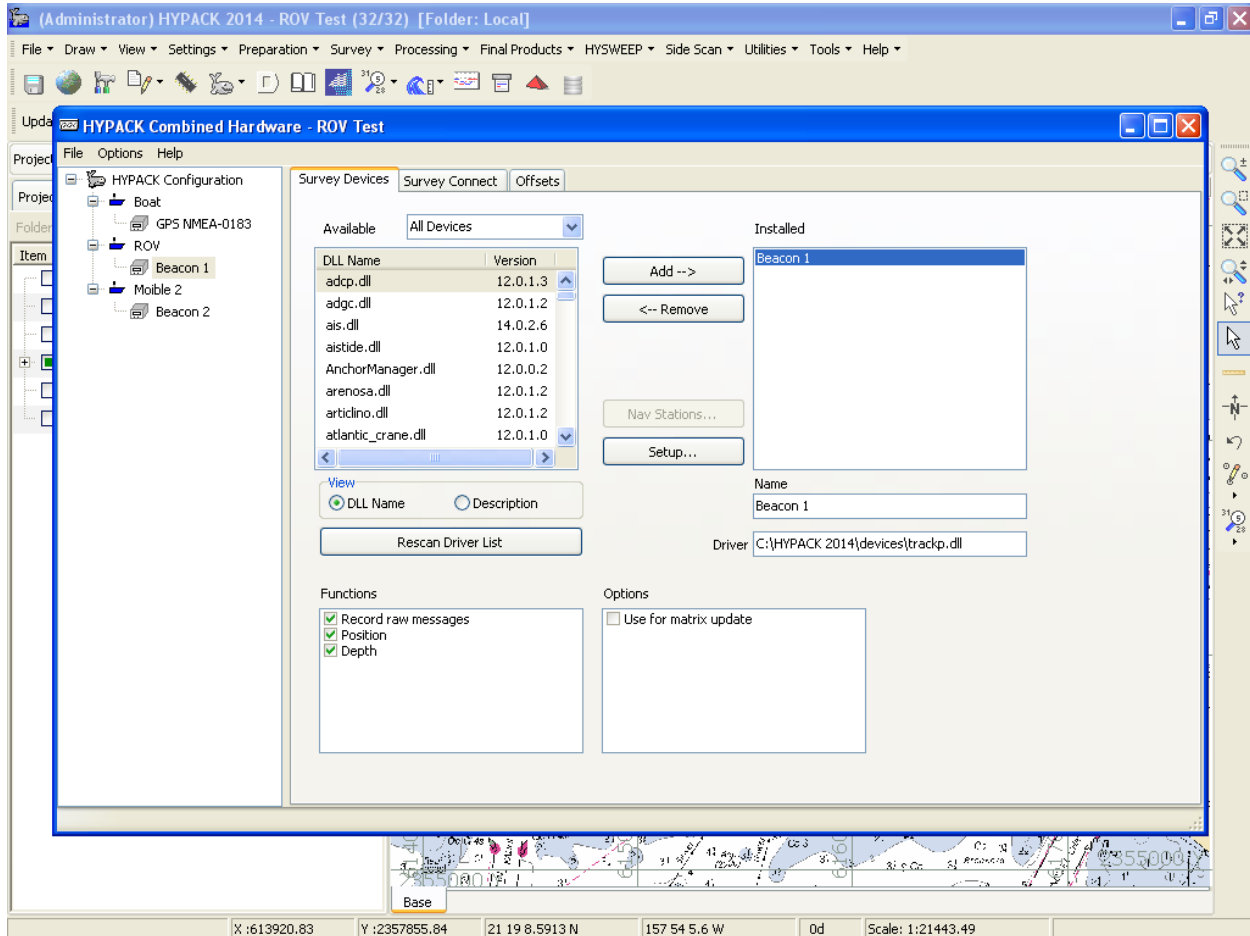

Figure 3-10 Hypack Hardware Settings

The Hypack map display and data are shown in Figure 3-11 and Figure 3-12. The map shows the position of the Boat, ROV, and Mobile 2 in the yard at SEI's Nimitz office. The data for each beacon is shown in the middle of the display. This data includes the relative distance (X, Y, and Z), range, and bearing. The left side of the display is the data from the GPS unit. Hypack will account for the offsets of the transducer and GPS receiver if they are entered into the software.

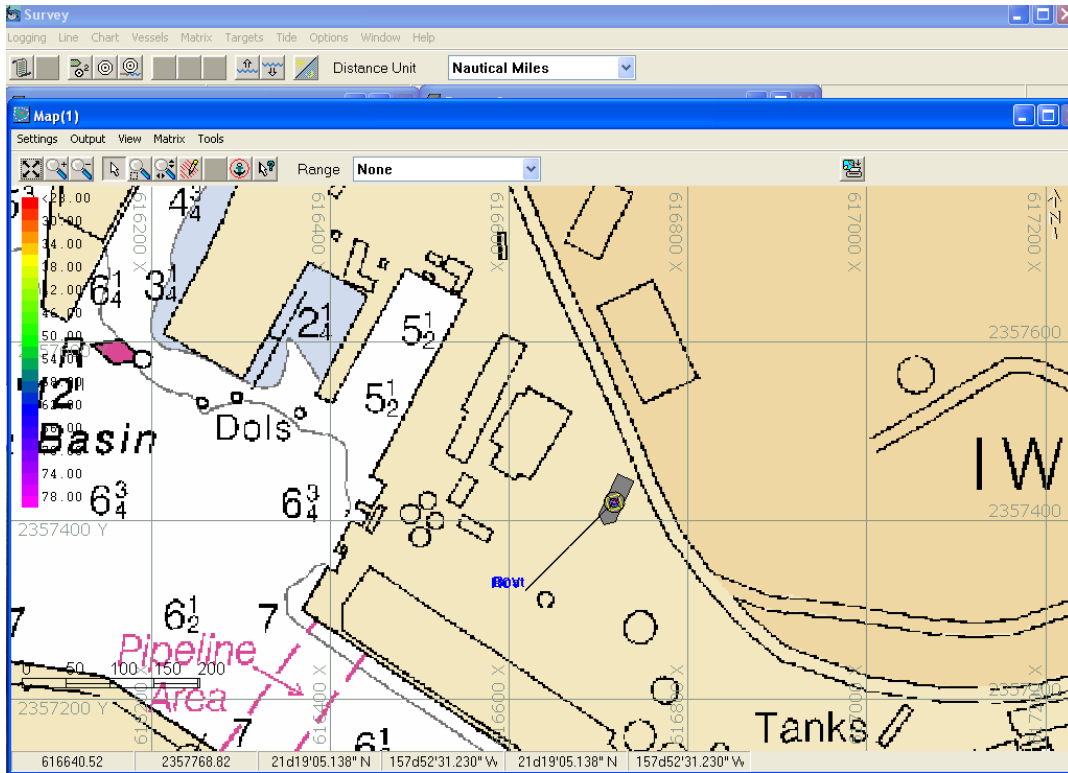

Figure 3-11 Hypack Map Display

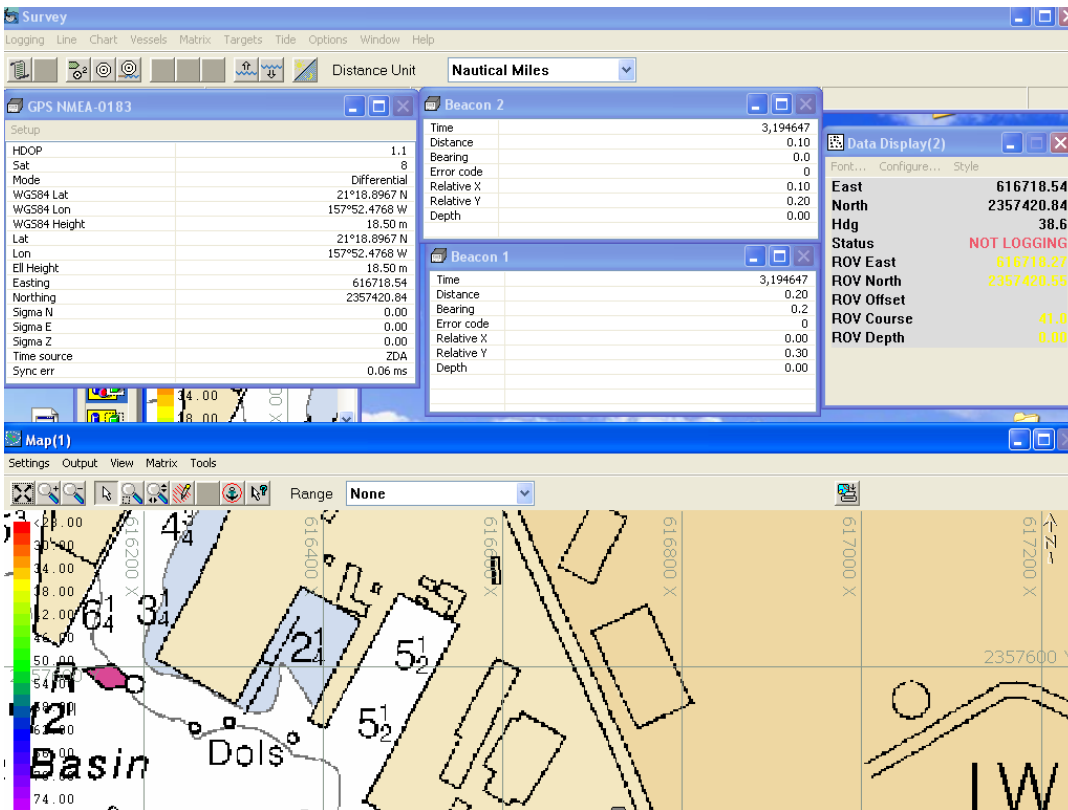

Figure 3-12 Hypack Data Display

4. SUMMARY

SEI developed standardized means to document the maintenance and modifications of the ROV which were presented in the previous operational assessment report. Modifications to the deck winch continued with the replacement of the fixed junction box and the reduction in height of the rotating junction box. These modifications increase the ease of servicing the terminations inside the boxes.

The update of the Subcan software allowed the use of the Schilling Bear Paw to control the second manipulator.

The integration of the Applied Acoustic USBL system allow the tracking of the ROV and the positioning of subsurface features. The USBL provided ROV position will be displayed in conjunction with the pertinent maps and overlays within the Hypack software. This display will aide navigation and positioning of the ROV and surface vessel.

The Super Mohawk ROV is operational, and can be currently utilized from SEI's vessel, *Huki Pau* or another vessel of opportunity should the need at WETS arise. Once shipbuilding operations on-board *Kūpa'a* are complete, the Super Mohawk ROV will be loaded and tested on-board the WETS dedicated vessel as well.

5. APPENDIX I: FIXED JUNCTION BOX TERMINATION



Procedure Name: Fixed Junction Box Termination

Description: Termination of the fixed junction box on the slip ring of the deck winch. The deck cable that connects the surface control unit (SCU) to the slip ring is terminated in the fixed junction box. The deck cable enters the fixed junction box the 3-phase 440-volt power for the thrusters, 1-phase 240-volt power for electronics, and optical fibers for communication. This document details the connections made in fixed junction box. The termination of the fixed junction box should be done after the deck cable is connect to the SCU via the large plug and the generator has been connected to the container.



Revision List:

1/3/2018	A	Original Document
5/8/2018	B	Modified for larger junction box

Attachments:

1	Longline wiring diagram



Fixed Junction Box Termination
 Version: B
 5/8/2018

Secure Power

At this point the in the mobilization procedure the generator has been terminated to the container and the deck cable is connected to the SCU. All circuit breakers are OFF and no power is supplied to the system. The circuit breakers for the ROV transformer and the deck winch are open (OFF).

Slip ring

The slip ring connects the fixed (non-rotating) deck cable to the tether (rotating). The electrical connections are maintained using rings and the fiber connections are made using prisms or mirrors. There are two junction boxes attached to the slip ring, one on either side of the slip ring, the fixed and rotating junction box. The rotating junction is inside the deck winch drum, and generally remains connected to the tether.

Fixed Junction Box

The deck cable is disconnected from the from the slip ring at the fixed junction box. The deck cable has many multiple wires that are unused for the current ROV setup. These wires are linked together in separate terminal block in the fixed junction box and grounded. This is shown in the picture on the first page of the procedure. The table to the right will show the connections to be made. Be sure to check each connection by pulling the wire to confirm that it is secure. Inspect the junction box lid and seal and close the box. Mount the box on the slip ring cage.

Fixed Junction Box

Detail	Use	Deck Cable	Slip Ring
3-phase 440 volt	Phase 1	Violet 1	Red 2
		Violet 2	
		Brown	
	Phase 2	Yellow 3	Red 3
		Yellow 4	
		Red	
	Phase 3	White 5	Red 4
		White 6	
		Blue	
	N	Gray	Red 5
Gray			
1-phase 240 volt	ROV L	Clear 8	Red 6
	ROV N	Orange 9	Red 7
Ground	Earth	Green	Green 1
CP Probe	TP	Clear 10	White 10
		Yellow 11	Black 9
	Shielding	Shielding/black 12	Shielding 8
Optical Fibers	ROV	Clear 1	Yellow 12
	Survey	Clear 2	Yellow 13
	Spare	Clear 3	Yellow 14
	Spare	Clear 4	Yellow 15
Ground		All Used wires	Green 1



Fixed Junction Box Termination
Version: B
5/8/2018



3-phase 440V with neutral connections for thruster power (3 wires for deck cable side)

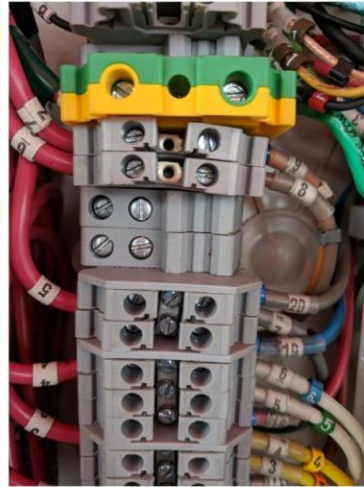

At top, single phase 220V (hot, neutral, and ground)

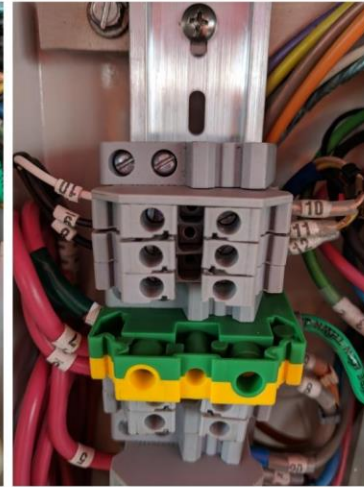

At top, The three wires for the CP probe.



grounded in together in the fixed JB.



Fiber routing with all connectors.

6. APPENDIX II: ROTATING JUNCTION BOX TERMINATION



Rotating Junction Box Termination
 Version: B
 4/28/2018

Procedure Name: Rotating Junction Box Termination

Description: Termination of the rotating junction box on the slip ring of the deck winch. The deck cable that connects the surface control unit (SCU) to the slip ring is terminated in the fixed junction box. The slip ring is terminated to the tether in the rotating junction box. The slipring wires enter the rotating junction box as 3-phase 440-volt power for the thrusters, 1-phase 240-volt power for electronics, and optical fibers for communication. This document details the connections made in rotating junction box. The termination of the rotating junction box should be done after the fixed junction box is connect to the SCU via the large plug and the generator has been connected to the container. **NO POWER SHOULD BE ON!**



Revision List:

4/20/2018	A -	Original Document
4/28/2018	B	Modification to make JB shorter

Attachments:

1	Slip ring drawing



Secure Power

At this point in the mobilization procedure the generator has been terminated to the container, the deck cable is connected to the SCU, and the deck is connected to the fixed junction box of the slip ring. All circuit breakers are OFF and no power is supplied to the system. The circuit breakers for the ROV transformer and the deck winch are open (OFF).

Slip ring

The slip ring connects the fixed (non-rotating) deck cable to the tether (rotating). The electrical connections are maintained using rings and the fiber connections are made using prisms or mirrors. There are two junction boxes attached to the slip ring, one on either side of the slip ring, the fixed and rotating junction box. The rotating junction is inside the deck winch drum, and generally remains connected to the tether.

Rotating Junction Box

The rotating junction box connects slip ring to tether. The rotating junction box was modified from its original state to allow the box to be removed from inside the winch drum to service. Otherwise the tether has to be removed from the drum to assess the junction box from the inner drum plate. The table to the right will show the connections to be made. Be sure to check each connection by pulling the wire to confirm that it is secure. Inspect the junction box lid and seal and close the box. Mount the box inside the winch drum. This may require some positioning of the tether and slip ring cable so that it can be fully inserted into the winch drum. The rotating junction box was modified to allow it to be removed from the winch drum without removing the tether from the winch.

Rotating Junction Box

Detail	Use	Slip Ring	Tether
3-phase 440 volt	Phase 1	Red 2	Gray #1 Orange #1
	Phase 2	Red 3	Red #2 Black #2
	Phase 3	Red 4	Pink #3 Violet #3
	N	Red 5	Blue #4 Brown #4
1-phase 240 volt	ROV L	Red 6	Yellow #5
	ROV N	Red 7	White #6
Ground	Earth	Green 1	Green "Earth"
CP Probe	Twisted Pair	White 10 Black 9	Red Blue
	Shielding	Shielding 8	Black
Optical Fibers	ROV	Yellow 12	Orange
	Survey	Yellow 13	Clear
	Spare	Yellow 14	Blue
	Spare	Yellow 15	Yellow



Rotating Junction Box Termination
Version: B
4/28/2018



Single Phase 240V power (6,7) and CP probe twisted pair (8,9,10)

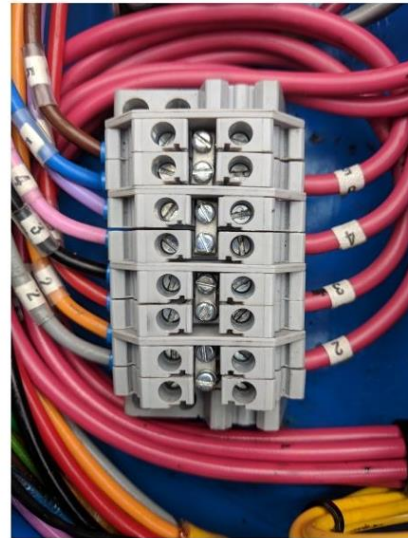

Three phase power connections

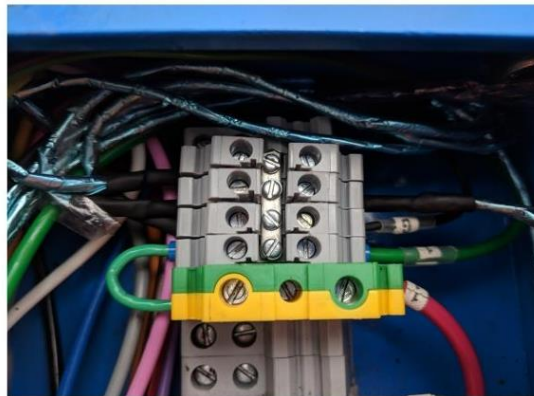

Grounding connections of unused wires (blue foil x 4) and shielding wire (black heat shrink)



Fiber connections are tie wrapped to the wall of the junction box so to not move when rotating in the winch drum



Rotating Junction Box Termination
 Version: B
 4/28/2018

